

LoRa OTA RF Performance Measurement Report for Schneider Electric IAQoverLoRa (MVP)



Report Reference:
MDE_LCIE_1903_OTA_01

Date:
25.11.2019

Test Laboratory:

7layers GmbH
Borsigstrasse 11
40880 Ratingen
Germany



Note:

The following test results relate only to the devices specified in this document. This report shall not be reproduced in parts without the written approval of the test laboratory

7layers GmbH
Borsigstraße 11
40880 Ratingen, Germany
T +49 (0) 2102 749 0
F +49 (0) 2102 749 350

Geschäftsführer/
Managing Directors:
Frank Spiller
Bernhard Retka
Alexandre Norré-Oudard

Registergericht/registered:
Düsseldorf HRB 75554
USt-Id.-Nr./VAT-No. DE203159652
Steuer-Nr./TAX-No. 147/5869/0385

a Bureau Veritas
Group Company

www.7layers.com

CONTENTS

1	PROJECT AND RESULT SUMMARY	3
2	SIGNATURES	4
3	DESCRIPTION OF THE TEST ENVIRONMENT AND THE TEST PROCEDURE	5
3.1	Equipment	5
3.2	Test procedure	6
3.3	References and Standards Used	9
3.4	Measurement uncertainties	10
3.5	Orientation of EUT compared to a standard device	11
4	RESULTS AND ANTENNA PATTERN	12
4.1	End-device transmitter performance at 868.3 MHz	12
4.2	End-device transmitter performance at 865.1 MHz	16
4.3	End-device transmitter performance at 863.1 MHz	20
4.4	End-device transmitter performance at 869.525 MHz	24
4.5	End-device transmitter performance EIRP at different carrier powers	28
4.6	End-device receiver performance EIS, 868.3 MHz, Rx1, Datarate SF12	29
4.7	End-device receiver performance EIS, 865.1 MHz, Rx1, Datarate SF12	29
4.8	End-device receiver performance EIS, 863.1 MHz, Rx1, Datarate SF12	29
4.9	End-device receiver performance EIS, 869.525 MHz, Rx2, Datarate SF12	30
4.10	End-device receiver performance EIS, 869.525 MHz, Rx2, Datarate SF7	30

1 Project and Result Summary

EUT	Schneider Electric IAQoverLoRa (MVP)	Device (EUI)	000054FFFF00720F
		HW version	V4-EU
		SW version	IAQoverLoRa_v4_Certification_EU86
Test lab	7layers GmbH Borsigstr. 11 40880 Ratingen Germany	Set up	Free space (Test Mode CW)
		LoRaWAN spec. version	LW1.0.3
		Test start	18.09.2019
		Report date	25.11.2019
Customer	Schneider Electric 28 Rue Henri Tarze 38000, Grenoble France	Temperature (°C)	27.1
		Humidity (%)	34
		Report by	Dieter Sütthoff
		Approved by	Robert Machulec

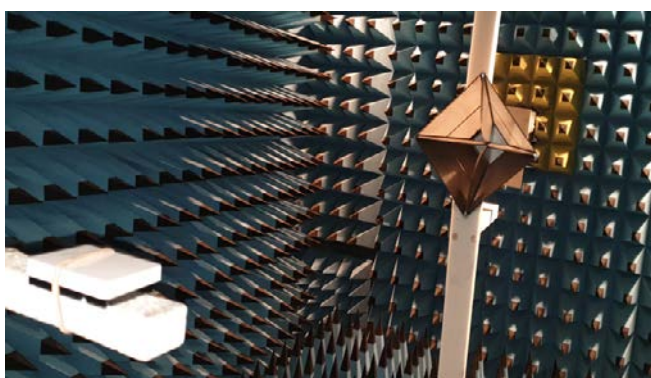

Fig. 1: Photo of test setup free space.

TX Powerstep	Results	863.1 MHz	865.1 MHz	868.3 MHz	869.525 MHz
0	EIRP (dBm) @ MaxEIRP carrier power	11.6	11.2	10.1	9.8
0	ERP (dBm) @ MaxEIRP carrier power	9.4	9.0	7.9	7.7
0	TRP (dBm) @ MaxEIRP carrier power	8.3	8.1	7.4	7.2
0	EIS (dBm) @ Datarate SF12	-133.8	-132.1	-133.8	-133.6
0	EIS (dBm) @ Datarate SF7				-121.3
3	EIRP (dBm) @ MaxEIRP - 6 dB carrier power	9.2	8.5	6.9	
6	EIRP (dBm) @ MaxEIRP - 12 dB carrier power	2.8	2.2	0.9	

Tab. 1: Summary measurement results.

Test Lab Declaration

All test results stated relate only to the device tested.

The test report must usually be reproduced in full. Reproduction of an excerpt is hereby granted, but only when:

- **in the resulting document it's status (being an excerpt) is clearly stated and**
- **in minimum chapter 1 is completely included.**

2 Signatures

Responsible for
Accreditation Scope:



Robert Machulec

Responsible
for Test Report:



Dieter Sütthoff

3 Description of the test environment and the test procedure

3.1 Equipment

The LoRa radiated RF performance is measurements in the 7 layers OTA Antenna Fully Anechoic Room (AFAR) which is CTIA Authorized Test Lab according to CTIA [2].

Ref.No.	Device Name	Description	Manufacturer	Serial Number	Last Calibration	Calibration Due
1.1	AFAR	Dimension: 6,7m x 3,4m x 3m	Albatross Projects		2019.03	2021.03
1.2	EMQuest	Measurement SW version 1.10	ETS	1179		
1.3	ETS3164-03	Dual polarized horn	ETS	00052619		
1.4	FSP3	spectrum analyser	R&S	838164/004	2018.12	2020.12
1.5	E5071B	Network Analyzer		MY42200813	2019.03	2021.03
1.6	RSP3	Step Attenuator	R&S	833695/001		
1.7	LORA Gateway	IOT SX301 Starter Kit	Semtech			

Measurement distance: $d_0 = 2.05$ m (horn antenna edge to center of turn table)

Nominal measurement distance: $d = 2.25$ m (antenna phase center mark to turn table)

Measurement Antenna: ETS 3164-03

Horn taper length: $a = 0.50$ m

Horn antenna aperture: $d_1 = 0.33$ m

3.2 Test procedure

The method of measurement for radiated RF power and receiver performance are according “LoRa Alliance End-Device Certification Radiated RF Performance for EU 868 MHz ISM Band Devices” [1].

End-device transmitter performance:

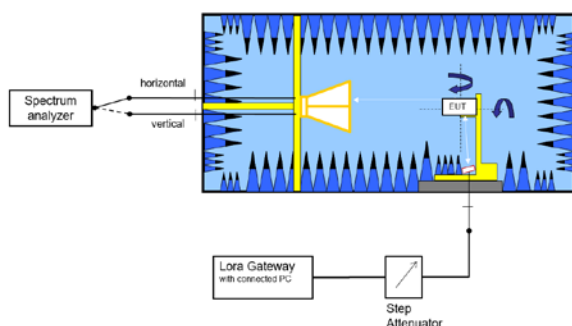

Fig. 1: Block diagram for TRP measurement

Measurement settings:

- Step width: 15°
- 3D radiation power pattern (both φ and θ directions)
- Antenna polarization: vertical and horizontal
- Receiver Detector: RMS
- Trace: Maxhold
- Resolution Bandwidth (RBW): 300 kHz
- Video Bandwidth (VBW): 300 kHz
- Sweep Time: 100 ms
- Span: Zero
- Selected Data Rate: SF12BW125

The EUT was placed at the turning device inside a fully anechoic chamber. A Lora Gateway was placed outside the chamber. A data connection between EUT and Lora Gateway was established. With a connected PC the Gateway and the EUT is controlled. The EUT was set in a Test mode and set to a LoRa transmission mode to the specified frequency. It was set to the maximum output power. The transmitter pattern was measured on the default 868.5 MHz.

The EIRP values are reported and the total radiated power (TRP) value was calculated.

The EIRP(ϕ, θ) was measured on different frequencies and with different output power levels. This is done at one point, test setup position and measurement antenna polarization. The measurement point was chosen based on the transmitter pattern measurement, where the maximum power was found (boresight position)

End-device receiver performance:

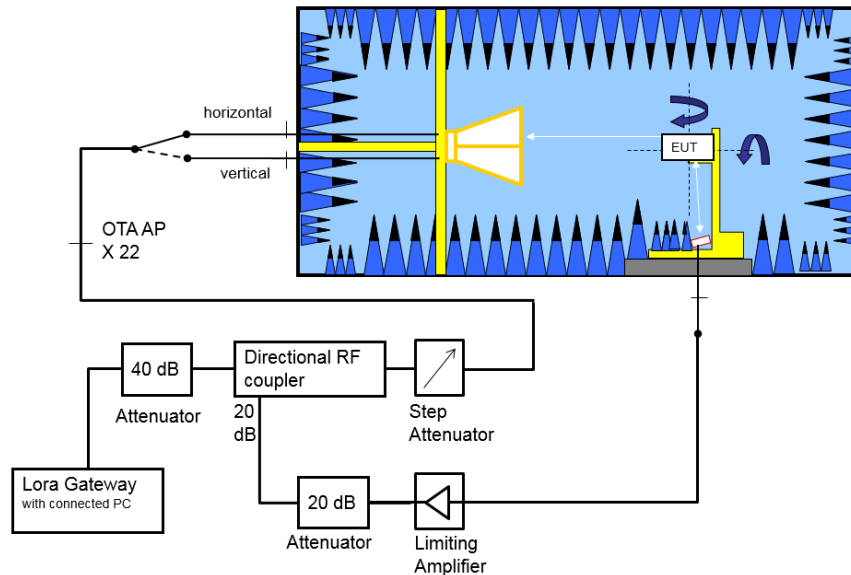

Fig. 2: Block diagram for TRS measurement

Receiver performance set up system parameters:

Output power Lora Gateway @ 868.5 MHz: 10.6 dBm

Attenuation 40 dB attenuator: 40 dB

Attenuation variable Step attenuator: 0 – 139.9 dBm, step 0.1 dB

Attenuation RF Cables and Directional coupler between Lora Gateway and OTA chamber Access point X22: 1.2 dB

Path loss at 868.5 MHz for theta polarization: 35.2 dB

Path loss at 868.5 MHz for phi polarization: 35.8 dB

The Effective Isotropic Sensitivity $EIS(\phi, \theta)$ was measured. This is done at one point, test setup position and measurement antenna polarization. The measurement point was chosen based on the transmitter pattern measurement, where the maximum power was found (boresight position). At this point the attenuation $A_{\text{step } 10\% \text{ PER}}$ of the communication link between the test set up and the LoRa Gateway was incised using a step attenuator up to the point where a PER of 10 % was measured on the PC. At least 60 downlink frames were measured. A attenuation steps resolution of 0.1 was used.

The Step Attenuator was set to 10 dB attenuation. The power P_{X22} 10 dB from the Lora Gateway was measured at the calibrated AP (Access Point) "X22" on the OTA Chamber.

The $EIS(\phi, \theta)$ (at boresight position ϕ, θ and polarization) value was calculated using following Equal:

$$EIS(\phi, \theta) = P_{X22 \text{ 10dB}} - \text{Path loss} + 10 \text{ dB} - A_{\text{step } 10\% \text{ PER}} \quad (1)$$

The Path loss values are determined during OTA Range Calibration according to CTIA [2] described in document “7layers OTA Germany Range Calibration” [4]. The path loss is the sum of NSA, cable attentions and Reference antenna gain between AP X22 and EUT

$$\text{Path loss} = (\text{NSA} + \text{Lcable} - \text{Gref}) \quad (2)$$

Lcable: Cables from AP X22 to OTA Measurement Antenna ETS3164-03

Gref: Gain of the measurement- and reference antenna

With the Network Analyzer E5071B the attenuation of all cables, attenuators, directional coupler and of the step attenuator was verified.

The final EIS value was calculated using relative antenna directivity (ϕ, θ) measured at boresight position and polarization during $EIRP(\phi, \theta)$ pattern measured in transmitter performance test ant using the Total EIRP value:

$$\text{EIS} = \text{EIS}(\phi_0, \theta_0) + \text{EIRP}(\phi_0, \theta_0) - \text{EIRP} \quad (3)$$

The total isotropic sensitivity (TIS) was calculated by using following equals:

$$\text{EIS}(\phi, \theta) = \text{EIS}(\phi_0, \theta_0) - (\text{EIRP}(\phi, \theta) - \text{EIRP}(\phi_0, \theta_0))$$

$$TIS = \frac{4\pi}{\oint \left(\frac{1}{EIS_{\phi}(\Omega, f)} + \frac{1}{EIS_{\theta}(\Omega, f)} \right)} \quad (4)$$

In the EUT power path a limiting amplifier was used to ensure the reception of sufficient dynamic range in the acknowledgement frame from the EUT and to ensured sufficient isolation between Tx and Rx path.

Definitions:

CTIA	Cellular Telecommunications & Internet Association
PER	Packet error rate
BS	Base station
EUT	Equipment under test
FS	Free space
NSA	Normalized Site Attenuation
TP	Talk position (phone is situated at SAM = human head phantom)
TRP	Total Radiated Power
TIS	Total Isotropic Sensitivity
TRS	Total Radiated Sensitivity (same as TIS in CTIA)
EIRP	Equivalent Isotropic Radiated Power
ERP	Effective radiated power
EIS	Effective Isotropic Sensitivity
SPO	Single Point Offset

3.3 References and Standards Used

- [1] LoRa Alliance End-Device Certification Radiated RF Performance for EU 868 MHz ISM Band Devices V1.2 (2019).
- [2] CTIA: "Test Plan for Wireless Device Over the Air Performance", Revision 3.8.2, 04/2019
- [3] 7 layers document: "7 layers Germany OTA Measurement Uncertainties", Version March 2019.
- [4] 7 layers document: "7 layers OTA Germany Range Calibration", Version March 2019.

3.4 Measurement uncertainties

Maxim Values	OTA lab at 7layers Germany [3]
TRP Free space	± 1.7 dB
TRS (EIS) Free space	± 2.1 dB

Standard specific table with the measurement uncertainties of the used parameters

The measurement uncertainties for all parameters are calculated with an expansion factor (coverage factor) $k = 1.96$. This means, that the true value is in the corresponding interval with a probability of 95 %.

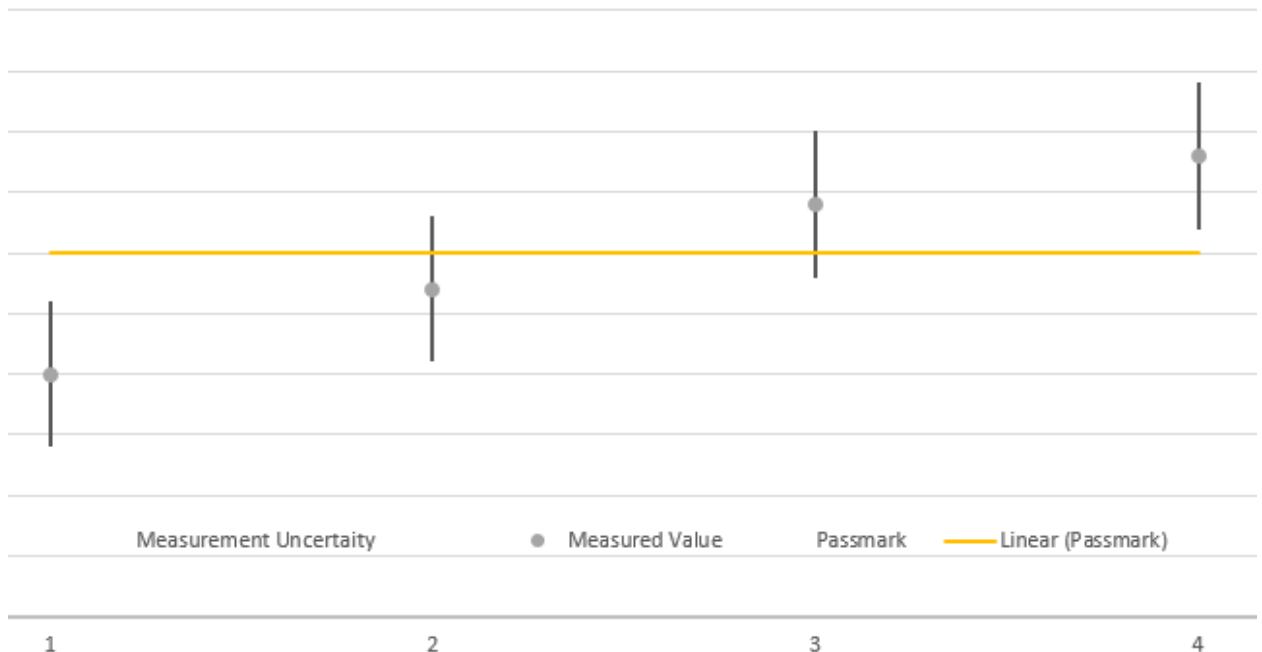

The verdicts in this test report are given according the above diagram:

Case	Measured Value	Uncertainty Range	Verdict
1	below pass mark	below pass mark	Passed
2	below pass mark	within pass mark	Passed
3	above pass mark	within pass mark	Failed
4	above pass mark	above pass mark	Failed

That means, the laboratory applies, as decision rule (see ISO/IEC 17025:2017), the so called shared risk principle.

3.5 Orientation of EUT compared to a standard device

For orientation of the EUT in the result pictures below the following photos illustrate the used orientation compared to a standard device:

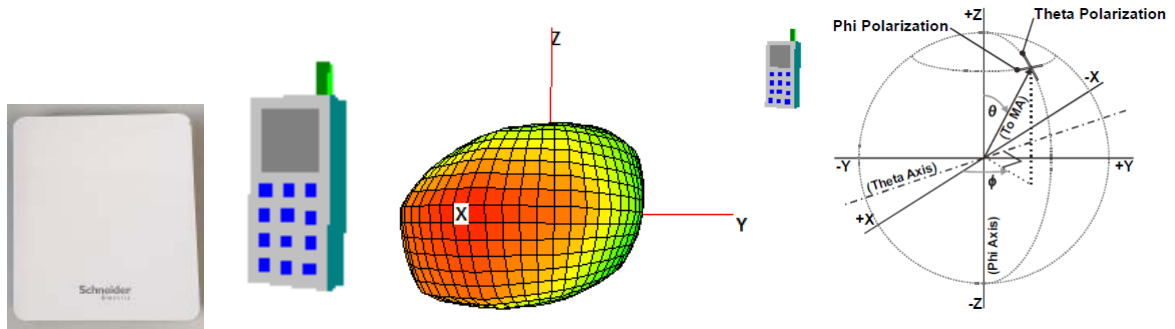

Fig. 2: Photo orientation of EUT compared to a phone.

4 Results and antenna pattern

4.1 End-device transmitter performance at 868.3 MHz

Polarization	Theta	Phi	Total
Nominal Ant. Port Input Pwr. (dBm)	14.0	14.0	14.0
Tot. Rad. Pwr. (dBm)	4.9	3.8	7.4
Peak EIRP (dBm)	9.9	7.4	10.1
Peak ERP (dBm)	7.8	5.3	7.9
Directivity (dBi)	5.0	3.6	2.7
Efficiency 14dBm (dB)	-9.1	-10.2	-6.6
Efficiency 14dBm (%)	12.4	9.5	21.9
Gain 14dBm (dBi)	-4.1	-6.6	-3.9
NHPRP $\pm\pi/4$ (dBm)	3.7	2.4	6.1
NHPRP $\pm\pi/6$ (dBm)	2.4	1.0	4.7
Boresight Phi ($^\circ$)	240.0	165.0	225.0
Boresight Th. ($^\circ$)	135.0	90.0	135.0

Tab. 2: Summary Tx measurement results at 868.3 MHz.

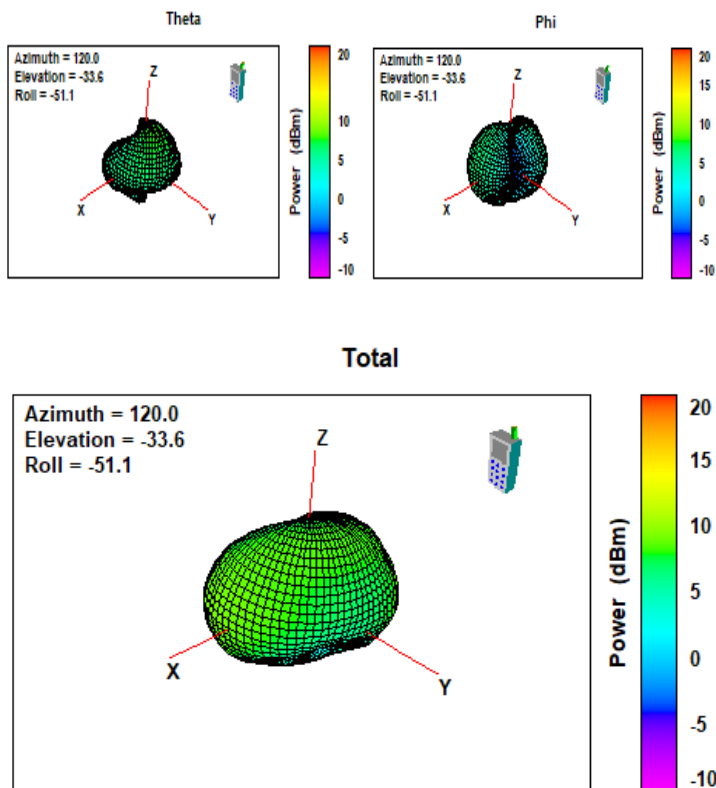

Fig. 3: 3D Pattern at 868.3 MHz.

Th 90° Phi (°)	FSP reading (dBm)	path loss (dB)	EIRP (dBm)	FSP reading (dBm)	path loss (dB)	EIRP (dBm)	EIRP (dBm)
	Polarisation Theta			Polarisation Phi			Total
360	-29.2	35.1	5.9	-29.5	35.8	6.3	9.1
345	-29.1	35.1	6.0	-28.9	35.8	6.8	9.5
330	-29.1	35.1	6.0	-29.1	35.8	6.7	9.4
315	-29.1	35.1	6.0	-29.9	35.8	5.9	9.0
300	-29.2	35.1	6.0	-31.3	35.8	4.4	8.3
285	-29.2	35.1	5.9	-33.8	35.8	1.9	7.4
270	-29.2	35.1	5.9	-38.2	35.8	-2.5	6.5
255	-29.2	35.1	5.9	-46.3	35.8	-10.6	6.0
240	-29.2	35.1	6.0	-42.4	35.8	-6.6	6.2
225	-29.1	35.1	6.0	-35.8	35.8	0.0	7.0
210	-29.1	35.1	6.1	-32.2	35.8	3.6	8.0
195	-29.1	35.1	6.1	-30.1	35.8	5.7	8.9
180	-29.1	35.1	6.1	-28.9	35.8	6.9	9.5
165	-29.2	35.1	6.0	-28.4	35.8	7.4	9.8
150	-29.3	35.1	5.8	-28.4	35.8	7.3	9.7
135	-29.5	35.1	5.7	-29.1	35.8	6.7	9.2
120	-29.6	35.1	5.5	-30.4	35.8	5.3	8.4
105	-29.8	35.1	5.4	-32.5	35.8	3.3	7.4
90	-29.8	35.1	5.3	-35.7	35.8	0.1	6.5
75	-29.8	35.1	5.3	-39.6	35.8	-3.9	5.8
60	-29.8	35.1	5.4	-39.6	35.8	-3.9	5.9
45	-29.6	35.1	5.5	-35.8	35.8	0.0	6.6
30	-29.4	35.1	5.7	-32.6	35.8	3.1	7.6
15	-29.3	35.1	5.8	-30.7	35.8	5.1	8.5
0	-29.2	35.1	5.9	-29.5	35.8	6.3	9.1

Tab. 3: Summary measurement results EIRP at 868.3 MHz X-Y plane.

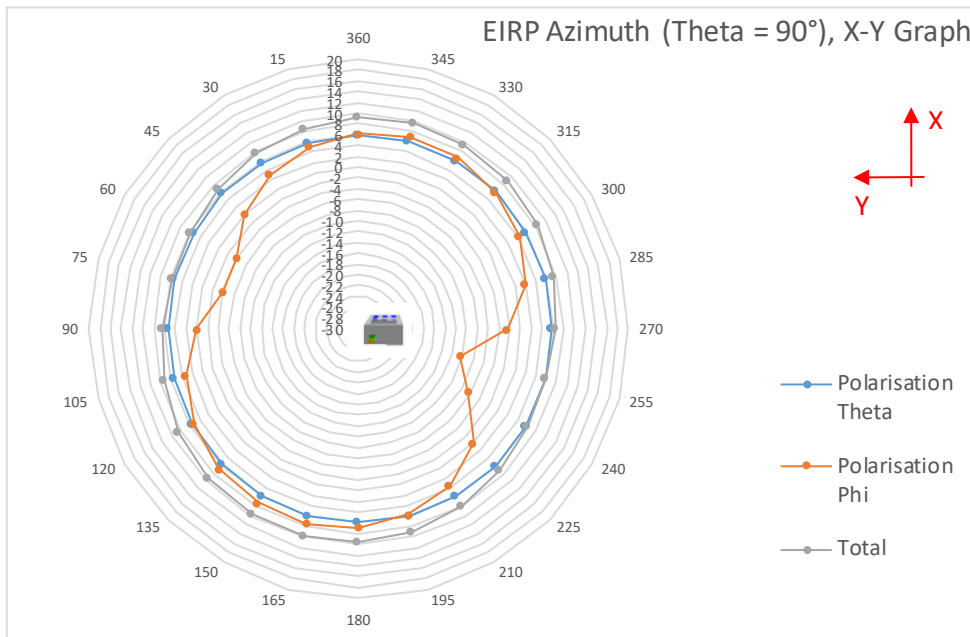

Fig. 4: 2D Pattern, X-Y plant at 868.3 MHz.

Phi = 0°	FSP reading (dBm)	path loss (dB)	EIRP (dBm)	FSP reading (dBm)	path loss (dB)	EIRP (dBm)	EIRP (dBm)
Theta	Pol Theta			Polarisation Phi			Total
0	-37.6	35.1	-2.4	-30.8	35.8	5.0	5.7
15	-33.1	35.1	2.1	-30.5	35.8	5.2	7.0
30	-30.9	35.1	4.3	-30.0	35.8	5.7	8.1
45	-30.0	35.1	5.2	-29.6	35.8	6.1	8.7
60	-29.6	35.1	5.5	-29.5	35.8	6.3	9.0
75	-28.9	35.1	6.2	-29.5	35.8	6.3	9.3
90	-29.2	35.1	5.9	-29.5	35.8	6.3	9.1
105	-30.6	35.1	4.6	-29.8	35.8	6.0	8.4
120	-33.2	35.1	2.0	-29.9	35.8	5.8	7.3
135	-37.5	35.1	-2.4	-30.7	35.8	5.1	5.8
150	-43.4	35.1	-8.2	-31.3	35.8	4.5	4.7
165	-45.1	35.1	-10.0	-30.8	35.8	5.0	5.1
180	-44.7	35.1	-9.6	-29.1	35.8	6.7	6.8
195	-32.9	35.1	2.2	-30.0	35.8	5.8	7.3
210	-29.8	35.1	5.3	-30.9	35.8	4.9	8.1
225	-28.3	35.1	6.9	-29.7	35.8	6.0	9.5
240	-27.9	35.1	7.2	-29.2	35.8	6.5	9.9
255	-28.3	35.1	6.9	-29.1	35.8	6.6	9.8
270	-29.1	35.1	6.1	-28.9	35.8	6.9	9.5
285	-31.7	35.1	3.4	-29.0	35.8	6.8	8.4
300	-35.2	35.1	-0.1	-29.8	35.8	6.0	6.9
315	-38.4	35.1	-3.3	-29.5	35.8	6.2	6.7
330	-45.8	35.1	-10.6	-29.6	35.8	6.2	6.3
345	-40.5	35.1	-5.4	-29.7	35.8	6.1	6.4
360	-37.6	35.1	-2.4	-30.8	35.8	5.0	5.7

Tab. 4: Summary measurement results EIRP at 868.3 MHz Z-X plane.

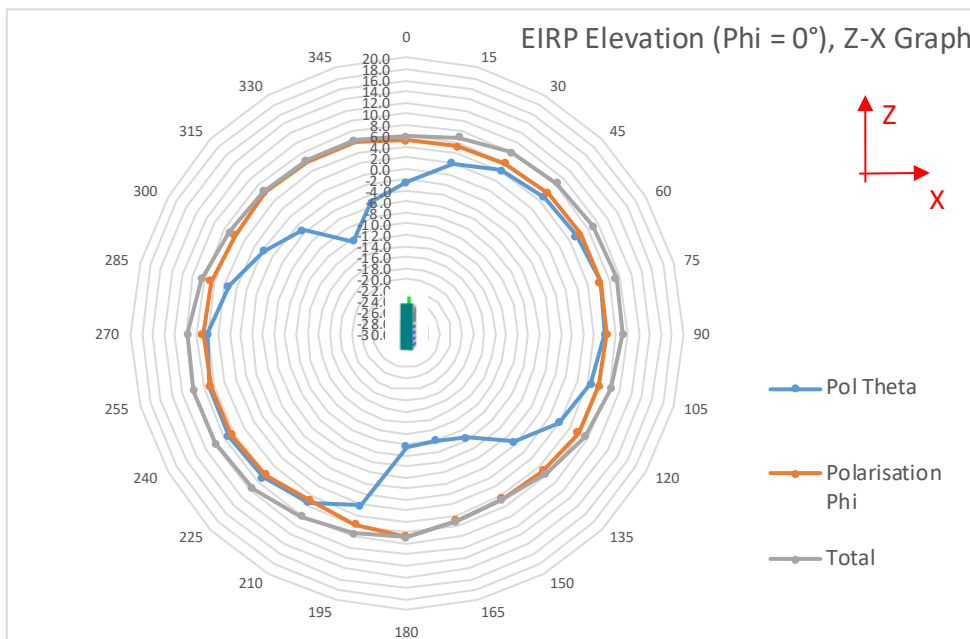

Fig. 5: 2D Pattern, Z-X plant at 868.3 MHz.

Phi 90° Theta	FSP reading (dBm)	path loss (dB)	EIRP (dBm)	FSP reading (dBm)	path loss (dB)	EIRP (dBm)	EIRP (dBm)
	Polarisation Theta			Polarisation Phi			Total
0	-30.1	35.1	5.0	-38.2	35.8	-2.4	5.7
15	-28.0	35.1	7.2	-37.2	35.8	-1.4	7.7
30	-27.3	35.1	7.9	-36.1	35.8	-0.4	8.5
45	-27.6	35.1	7.6	-36.6	35.8	-0.8	8.2
60	-28.6	35.1	6.5	-36.7	35.8	-1.0	7.3
75	-28.8	35.1	6.3	-37.9	35.8	-2.1	6.9
90	-29.8	35.1	5.3	-35.7	35.8	0.1	6.5
105	-32.0	35.1	3.1	-36.5	35.8	-0.8	4.6
120	-36.9	35.1	-1.7	-35.6	35.8	0.2	2.3
135	-48.5	35.1	-13.3	-36.7	35.8	-0.9	-0.7
150	-40.8	35.1	-5.7	-36.3	35.8	-0.6	0.6
165	-32.3	35.1	2.9	-36.5	35.8	-0.8	4.4
180	-28.4	35.1	6.7	-45.3	35.8	-9.6	6.8
195	-27.4	35.1	7.8	-36.7	35.8	-0.9	8.3
210	-26.7	35.1	8.5	-37.2	35.8	-1.4	8.9
225	-25.7	35.1	9.5	-39.3	35.8	-3.5	9.7
240	-26.4	35.1	8.7	-37.9	35.8	-2.1	9.1
255	-27.5	35.1	7.7	-38.9	35.8	-3.1	8.0
270	-29.2	35.1	5.9	-38.2	35.8	-2.5	6.5
285	-33.1	35.1	2.0	-39.2	35.8	-3.4	3.1
300	-38.4	35.1	-3.3	-37.4	35.8	-1.6	0.7
315	-57.1	35.1	-22.0	-39.1	35.8	-3.3	-3.3
330	-38.2	35.1	-3.0	-38.8	35.8	-3.0	0.0
345	-31.7	35.1	3.4	-39.8	35.8	-4.0	4.1
360	-30.1	35.1	5.0	-38.2	35.8	-2.4	5.7

Tab. 5: Summary measurement results EIRP at 868.3 MHz Z-Y plane.

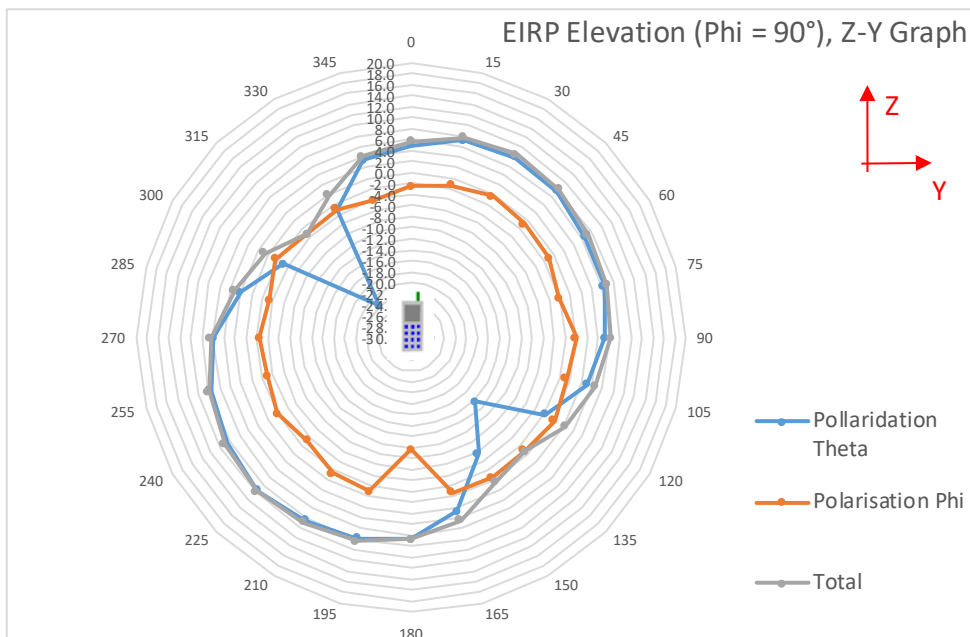

Fig. 6: 2D Pattern, Z-Y plant at 868.3 MHz.

4.2 End-device transmitter performance at 865.1 MHz

Polarization	Theta	Phi	Total
Nominal Ant. Port Input Pwr. (dBm)	14.0	14.0	14.0
Tot. Rad. Pwr. (dBm)	6.0	3.9	8.1
Peak EIRP (dBm)	11.1	7.6	11.2
Peak ERP (dBm)	8.9	5.5	9.0
Directivity (dBi)	5.0	3.7	3.0
Efficiency 14dBm (dB)	-8.0	-10.1	-5.9
Efficiency 14dBm (%)	15.9	9.8	25.8
Gain 14dBm (dBi)	-2.9	-6.4	-2.8
NHPRP $\pm\pi/4$ (dBm)	4.8	2.6	6.8
NHPRP $\pm\pi/6$ (dBm)	3.4	1.2	5.5
Boresight Phi ($^{\circ}$)	240.0	165.0	225.0
Boresight Th. ($^{\circ}$)	135.0	90.0	135.0

Tab. 6: Summary Tx measurement results at 865.1 MHz.

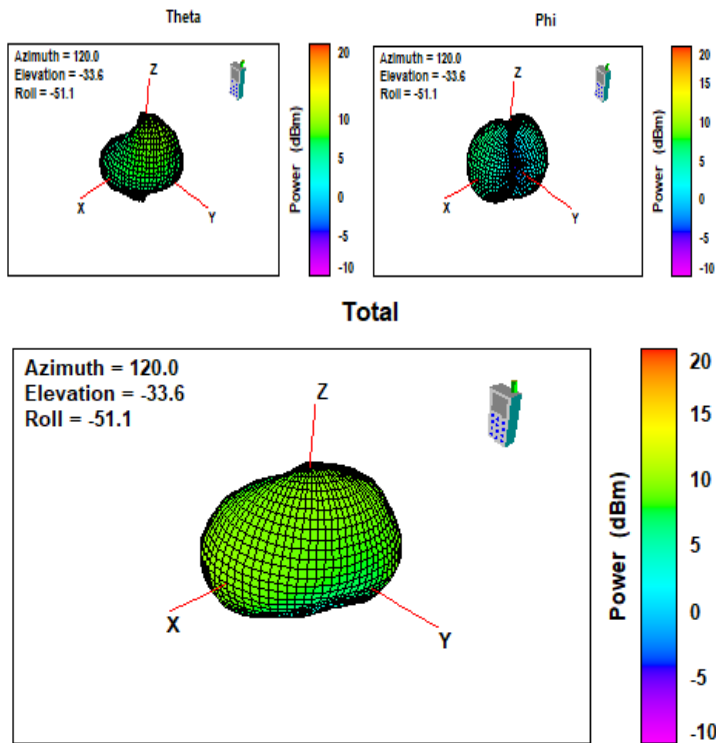

Fig. 7: 3D Pattern at 865.1 MHz.

Th 90° Phi (°)	FSP reading (dBm)	path loss (dB)	EIRP (dBm)	FSP reading (dBm)	path loss (dB)	EIRP (dBm)	EIRP (dBm)
	Polarisation Theta			Polarisation Phi			Total
360	-28.5	35.5	7.0	-29.4	35.7	6.3	9.7
345	-28.4	35.5	7.1	-28.8	35.7	6.9	10.0
330	-28.4	35.5	7.1	-28.9	35.7	6.8	10.0
315	-28.4	35.5	7.1	-29.7	35.7	6.1	9.6
300	-28.4	35.5	7.0	-31.1	35.7	4.6	9.0
285	-28.5	35.5	7.0	-33.5	35.7	2.3	8.3
270	-28.5	35.5	7.0	-37.6	35.7	-1.9	7.5
255	-28.4	35.5	7.1	-45.4	35.7	-9.6	7.1
240	-28.4	35.5	7.1	-42.8	35.7	-7.0	7.3
225	-28.3	35.5	7.2	-36.0	35.7	-0.3	7.9
210	-28.3	35.5	7.2	-32.3	35.7	3.5	8.7
195	-28.3	35.5	7.2	-30.0	35.7	5.7	9.5
180	-28.3	35.5	7.1	-28.7	35.7	7.0	10.1
165	-28.4	35.5	7.0	-28.1	35.7	7.6	10.3
150	-28.6	35.5	6.9	-28.2	35.7	7.6	10.2
135	-28.8	35.5	6.7	-28.8	35.7	7.0	9.8
120	-29.0	35.5	6.5	-30.0	35.7	5.7	9.1
105	-29.1	35.5	6.4	-32.1	35.7	3.7	8.3
90	-29.1	35.5	6.4	-35.2	35.7	0.5	7.4
75	-29.1	35.5	6.4	-39.2	35.7	-3.5	6.8
60	-29.0	35.5	6.5	-39.8	35.7	-4.1	6.8
45	-28.9	35.5	6.6	-36.0	35.7	-0.2	7.4
30	-28.7	35.5	6.8	-32.7	35.7	3.0	8.3
15	-28.6	35.5	6.9	-30.6	35.7	5.1	9.1
0	-28.5	35.5	7.0	-29.4	35.7	6.3	9.7

Tab. 7: Summary measurement results EIRP at 865.1 MHz X-Y plane.

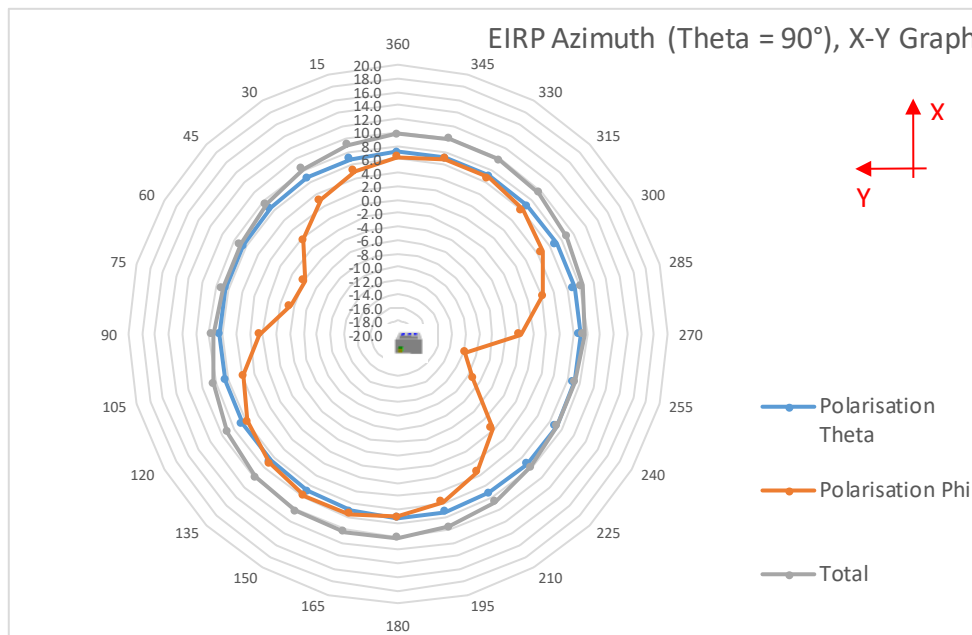

Fig. 8: 2D Pattern, X-Y plant at 865.1 MHz.

Phi = 0°	FSP reading (dBm)	NSA+Cable (dB)	EIRP (dBm)	FSP reading (dBm)	path loss (dB)	EIRP (dBm)	EIRP (dBm)
Theta	Pol Theta		Polarisation Phi				Total
0	-35.9	35.5	-0.5	-30.5	35.7	5.2	6.2
15	-31.8	35.5	3.7	-30.3	35.7	5.5	7.7
30	-29.8	35.5	5.7	-29.9	35.7	5.9	8.8
45	-29.0	35.5	6.5	-29.4	35.7	6.3	9.4
60	-28.7	35.5	6.8	-29.3	35.7	6.4	9.6
75	-28.1	35.5	7.4	-29.4	35.7	6.4	9.9
90	-28.5	35.5	7.0	-29.4	35.7	6.3	9.7
105	-30.0	35.5	5.5	-29.7	35.7	6.0	8.8
120	-33.0	35.5	2.5	-29.8	35.7	5.9	7.5
135	-37.8	35.5	-2.3	-30.6	35.7	5.1	5.9
150	-44.5	35.5	-9.0	-31.2	35.7	4.5	4.7
165	-42.8	35.5	-7.4	-30.7	35.7	5.1	5.3
180	-43.2	35.5	-7.8	-29.4	35.7	6.3	6.5
195	-31.9	35.5	3.6	-30.5	35.7	5.3	7.5
210	-28.9	35.5	6.6	-30.7	35.7	5.0	8.9
225	-27.4	35.5	8.1	-29.6	35.7	6.1	10.2
240	-27.1	35.5	8.4	-29.1	35.7	6.6	10.6
255	-27.5	35.5	8.0	-28.9	35.7	6.8	10.5
270	-28.3	35.5	7.1	-28.7	35.7	7.0	10.1
285	-31.1	35.5	4.3	-28.9	35.7	6.9	8.8
300	-34.7	35.5	0.8	-29.7	35.7	6.1	7.2
315	-38.0	35.5	-2.5	-29.4	35.7	6.4	6.9
330	-44.8	35.5	-9.3	-29.4	35.7	6.3	6.4
345	-38.9	35.5	-3.4	-29.5	35.7	6.2	6.7
360	-35.9	35.5	-0.5	-30.5	35.7	5.2	6.2

Tab. 8: Summary measurement results EIRP at 865.1 MHz Z-X plane.

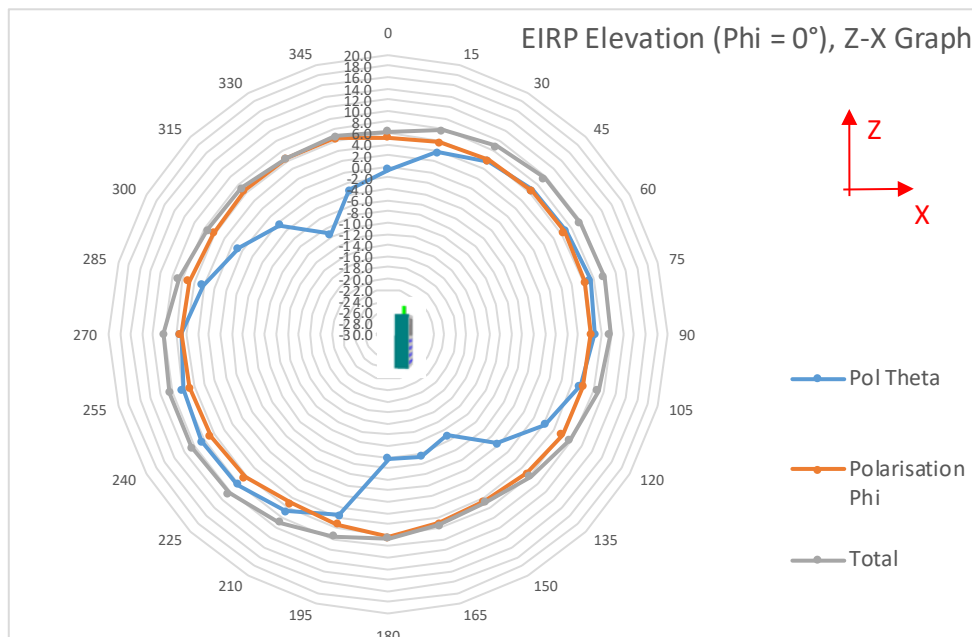

Fig. 9: 2D Pattern, Z-X plant at 865.1 MHz.

Phi 90°	FSP reading (dBm)	path loss (dB)	EIRP (dBm)	FSP reading (dBm)	path loss (dB)	EIRP (dBm)	EIRP (dBm)
Theta	Polarisation Theta			Polarisation Phi			Total
0	-30.3	35.5	5.2	-36.2	35.7	-0.5	6.2
15	-27.1	35.5	8.4	-36.6	35.7	-0.8	8.9
30	-26.4	35.5	9.1	-35.6	35.7	0.1	9.6
45	-26.7	35.5	8.8	-35.9	35.7	-0.2	9.3
60	-27.8	35.5	7.7	-36.1	35.7	-0.4	8.3
75	-28.1	35.5	7.4	-37.3	35.7	-1.6	7.9
90	-29.1	35.5	6.4	-35.2	35.7	0.5	7.4
105	-31.4	35.5	4.1	-35.9	35.7	-0.2	5.5
120	-36.5	35.5	-1.0	-35.1	35.7	0.6	2.9
135	-48.0	35.5	-12.5	-36.1	35.7	-0.4	-0.1
150	-39.7	35.5	-4.3	-35.9	35.7	-0.1	1.3
165	-32.2	35.5	3.3	-36.8	35.7	-1.0	4.6
180	-29.1	35.5	6.3	-43.5	35.7	-7.8	6.5
195	-26.8	35.5	8.7	-36.9	35.7	-1.1	9.1
210	-26.0	35.5	9.5	-36.8	35.7	-1.1	9.9
225	-25.0	35.5	10.5	-38.7	35.7	-3.0	10.7
240	-25.7	35.5	9.8	-37.2	35.7	-1.5	10.1
255	-26.7	35.5	8.8	-38.1	35.7	-2.4	9.1
270	-28.5	35.5	7.0	-37.6	35.7	-1.9	7.5
285	-32.4	35.5	3.1	-38.3	35.7	-2.6	4.2
300	-37.5	35.5	-2.0	-36.8	35.7	-1.1	1.5
315	-57.2	35.5	-21.7	-38.3	35.7	-2.6	-2.5
330	-37.5	35.5	-2.1	-37.8	35.7	-2.1	0.9
345	-31.0	35.5	4.5	-38.8	35.7	-3.1	5.2
360	-30.3	35.5	5.2	-36.2	35.7	-0.5	6.2

Tab. 9: Summary measurement results EIRP at 865.1 MHz Z-Y plane.

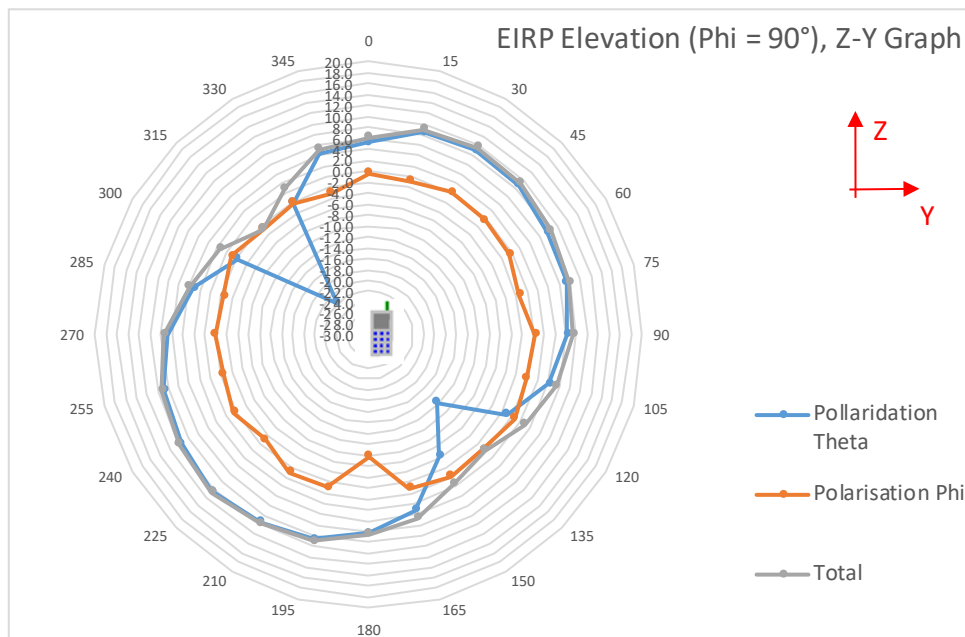

Fig. 10: 2D Pattern, Z-X plant at 865.1 MHz.

4.3 End-device transmitter performance at 863.1 MHz

Polarization	Theta	Phi	Total
Ant. Port Input Pwr. (dBm)	14.0	14.0	14.0
Tot. Rad. Pwr. (dBm)	6.1	4.3	8.3
Peak EIRP (dBm)	11.5	7.9	11.6
Peak ERP (dBm)	9.4	5.8	9.4
Directivity (dBi)	5.4	3.6	3.3
Efficiency 14dBm (dB)	-7.9	-9.7	-5.7
Efficiency 14dBm (%)	16.2	10.6	26.8
Gain 14dBm (dBi)	-2.5	-6.1	-2.4
NHPRP $\pm\pi/4$ (dBm)	4.8	2.9	7.0
NHPRP $\pm\pi/6$ (dBm)	3.4	1.5	5.6
Boresight Phi ($^{\circ}$)	240.0	165.0	240.0
Boresight Th. ($^{\circ}$)	135.0	90.0	135.0

Tab. 10: Summary Tx measurement results at 863.1 MHz.

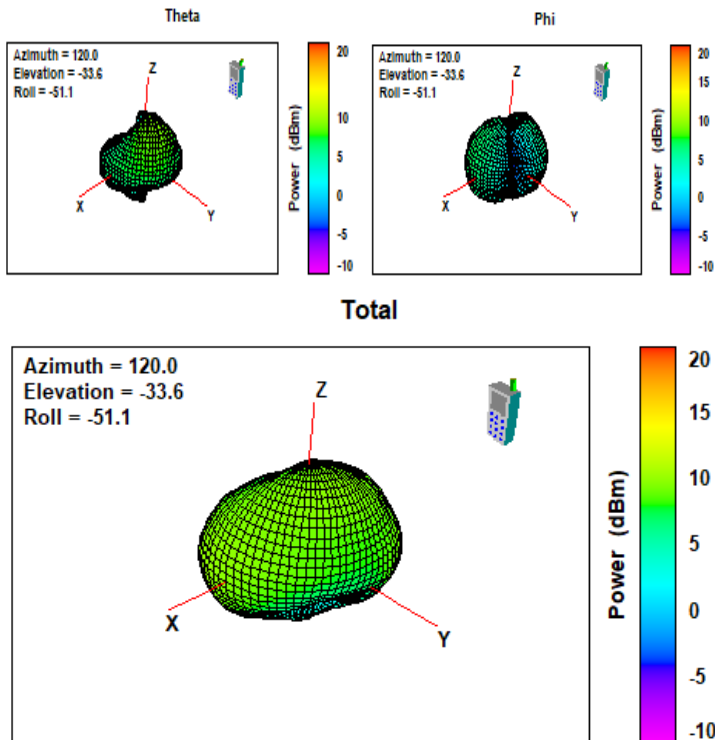

Fig. 11: 3D Pattern at 863.1 MHz.

Th 90° Phi (°)	FSP reading (dBm)	path loss (dB)	EIRP (dBm)	FSP reading (dBm)	path loss (dB)	EIRP (dBm)	EIRP (dBm)
	Polarisation Theta			Polarisation Phi			Total
360	-29.0	35.7	6.7	-29.0	35.7	6.7	9.7
345	-28.9	35.7	6.8	-28.4	35.7	7.3	10.1
330	-28.8	35.7	6.9	-28.5	35.7	7.2	10.0
315	-28.8	35.7	6.9	-29.3	35.7	6.4	9.7
300	-28.8	35.7	6.9	-30.7	35.7	5.0	9.1
285	-28.8	35.7	6.9	-33.1	35.7	2.6	8.3
270	-28.8	35.7	6.9	-37.2	35.7	-1.6	7.5
255	-28.7	35.7	7.0	-45.2	35.7	-9.5	7.1
240	-28.6	35.7	7.1	-42.4	35.7	-6.7	7.2
225	-28.6	35.7	7.1	-35.6	35.7	0.1	7.9
210	-28.5	35.7	7.2	-31.8	35.7	3.8	8.8
195	-28.5	35.7	7.2	-29.6	35.7	6.1	9.7
180	-28.5	35.7	7.2	-28.3	35.7	7.3	10.3
165	-28.6	35.7	7.1	-27.8	35.7	7.9	10.5
150	-28.8	35.7	6.9	-27.8	35.7	7.9	10.4
135	-29.0	35.7	6.7	-28.4	35.7	7.2	10.0
120	-29.2	35.7	6.5	-29.7	35.7	6.0	9.3
105	-29.3	35.7	6.4	-31.7	35.7	4.0	8.3
90	-29.5	35.7	6.2	-34.8	35.7	0.9	7.3
75	-29.5	35.7	6.2	-38.8	35.7	-3.2	6.7
60	-29.4	35.7	6.3	-39.4	35.7	-3.8	6.7
45	-29.3	35.7	6.4	-35.6	35.7	0.1	7.3
30	-29.2	35.7	6.5	-32.3	35.7	3.3	8.2
15	-29.1	35.7	6.6	-30.2	35.7	5.4	9.1
0	-29.0	35.7	6.7	-29.0	35.7	6.7	9.7

Tab. 11: Summary measurement results EIRP at 863.1 MHz X-Y plane.

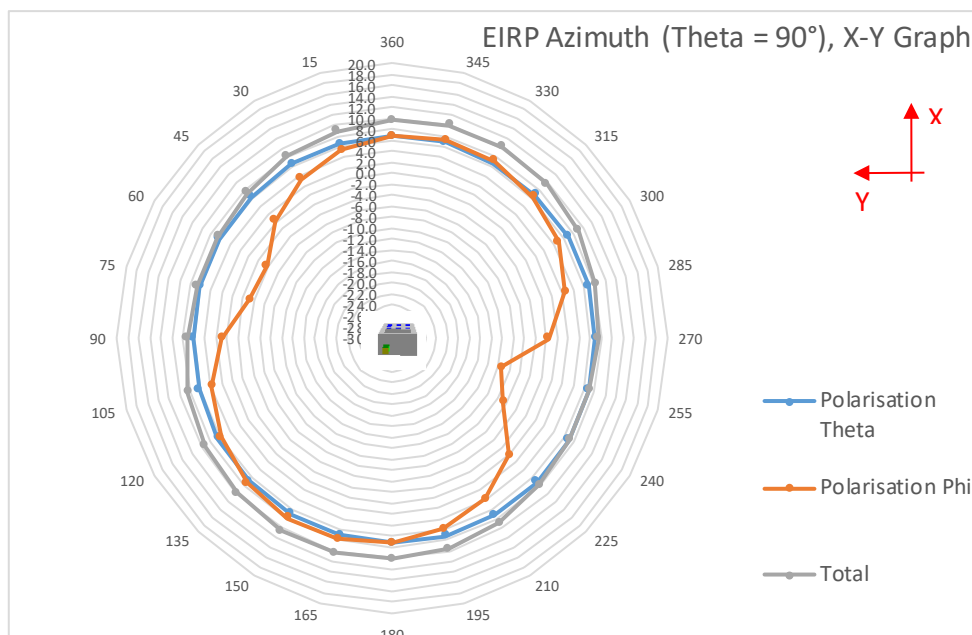

Fig. 12: 2D Pattern, X-Y plant at 863.1 MHz.

Phi = 0°	FSP reading (dBm)	path loss (dB)	EIRP (dBm)	FSP reading (dBm)	path loss (dB)	EIRP (dBm)	EIRP (dBm)
Theta	Pol Theta			Polarisation Phi			Total
0	-35.7	35.7	-0.1	-30.1	35.7	5.6	6.6
15	-32.0	35.7	3.7	-29.9	35.7	5.8	7.9
30	-30.2	35.7	5.5	-29.5	35.7	6.2	8.8
45	-29.4	35.7	6.3	-29.1	35.7	6.6	9.4
60	-29.1	35.7	6.6	-29.0	35.7	6.7	9.6
75	-28.5	35.7	7.2	-29.0	35.7	6.7	10.0
90	-29.0	35.7	6.7	-29.0	35.7	6.7	9.7
105	-30.5	35.7	5.2	-29.2	35.7	6.4	8.9
120	-33.4	35.7	2.3	-29.3	35.7	6.4	7.8
135	-38.4	35.7	-2.7	-30.0	35.7	5.7	6.3
150	-45.4	35.7	-9.7	-30.5	35.7	5.1	5.3
165	-42.1	35.7	-6.4	-30.0	35.7	5.7	6.0
180	-43.5	35.7	-7.9	-28.8	35.7	6.9	7.0
195	-31.9	35.7	3.8	-29.8	35.7	5.9	8.0
210	-28.8	35.7	6.9	-30.1	35.7	5.6	9.3
225	-27.4	35.7	8.3	-29.0	35.7	6.6	10.5
240	-27.2	35.7	8.5	-28.6	35.7	7.1	10.9
255	-27.7	35.7	8.0	-28.5	35.7	7.1	10.6
270	-28.5	35.7	7.2	-28.3	35.7	7.3	10.3
285	-31.3	35.7	4.4	-28.4	35.7	7.3	9.1
300	-35.3	35.7	0.4	-29.3	35.7	6.4	7.3
315	-39.3	35.7	-3.6	-29.2	35.7	6.5	6.9
330	-44.4	35.7	-8.8	-29.2	35.7	6.5	6.6
345	-38.9	35.7	-3.2	-29.2	35.7	6.5	6.9
360	-35.7	35.7	-0.1	-30.1	35.7	5.6	6.6

Tab. 12: Summary measurement results EIRP at 865.1 MHz Z-X plane.

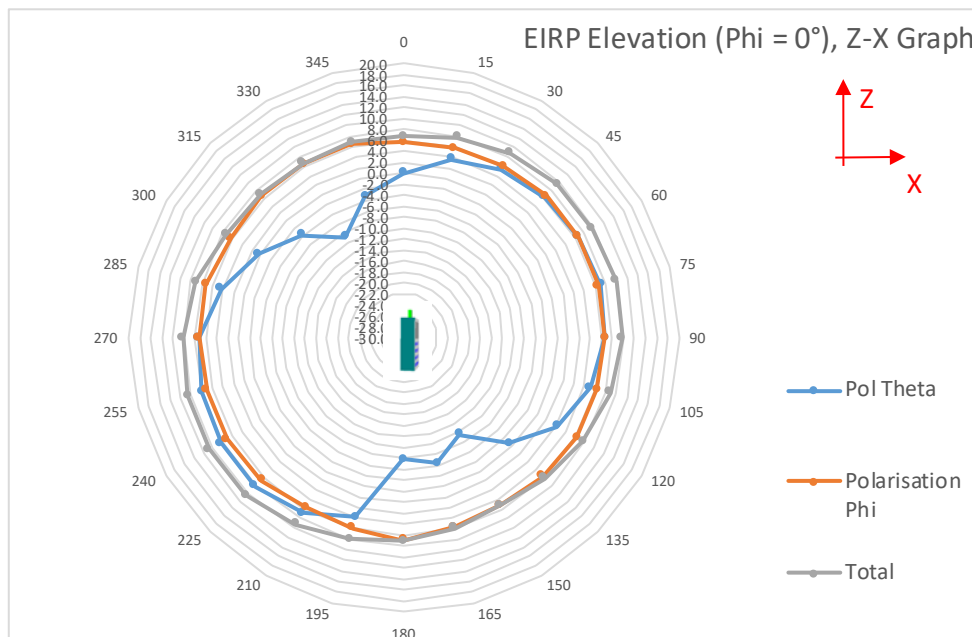

Fig. 13: 2D Pattern, Z-X plant at 863.1 MHz.

Phi 90° Theta	FSP reading (dBm)	path loss (dB)	EIRP (dBm)	FSP reading (dBm)	path loss (dB)	EIRP (dBm)	EIRP (dBm)
	Polarisation Theta			Polarisation Phi			Total
0	-30.1	35.7	5.6	-35.7	35.7	-0.1	6.6
15	-27.1	35.7	8.6	-36.4	35.7	-0.7	9.1
30	-26.6	35.7	9.1	-35.5	35.7	0.1	9.6
45	-27.0	35.7	8.7	-36.0	35.7	-0.4	9.2
60	-28.1	35.7	7.6	-36.0	35.7	-0.4	8.3
75	-28.2	35.7	7.5	-36.7	35.7	-1.0	8.1
90	-29.5	35.7	6.2	-34.8	35.7	0.9	7.3
105	-32.0	35.7	3.7	-35.7	35.7	0.0	5.2
120	-37.8	35.7	-2.1	-34.8	35.7	0.9	2.6
135	-45.4	35.7	-9.7	-35.8	35.7	-0.2	0.3
150	-37.7	35.7	-2.0	-35.5	35.7	0.2	2.2
165	-31.2	35.7	4.5	-36.3	35.7	-0.7	5.6
180	-28.8	35.7	6.9	-43.5	35.7	-7.9	7.0
195	-26.4	35.7	9.3	-36.5	35.7	-0.8	9.7
210	-25.6	35.7	10.1	-36.2	35.7	-0.6	10.5
225	-24.7	35.7	11.0	-38.2	35.7	-2.5	11.2
240	-25.6	35.7	10.1	-36.9	35.7	-1.3	10.4
255	-26.8	35.7	8.9	-37.8	35.7	-2.2	9.2
270	-28.8	35.7	6.9	-37.2	35.7	-1.6	7.5
285	-33.0	35.7	2.7	-38.0	35.7	-2.4	3.9
300	-39.3	35.7	-3.6	-36.6	35.7	-0.9	1.0
315	-52.7	35.7	-17.1	-38.1	35.7	-2.4	-2.3
330	-36.5	35.7	-0.9	-37.6	35.7	-2.0	1.6
345	-31.0	35.7	4.7	-38.6	35.7	-2.9	5.4
360	-30.1	35.7	5.6	-35.7	35.7	-0.1	6.6

Tab. 13: Summary measurement results EIRP at 863.1 MHz Z-Y plane.

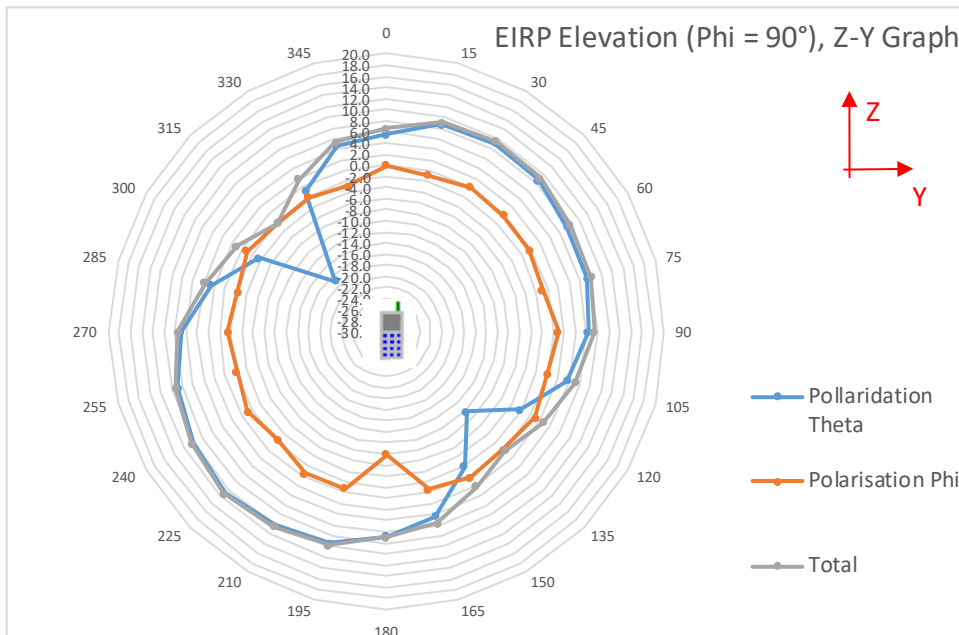

Fig. 14: 2D Pattern, Z-X plant at 863.1 MHz.

4.4 End-device transmitter performance at 869.525 MHz

Polarization	Theta	Phi	Total
Ant. Port Input Pwr. (dBm)	14.0	14.0	14.0
Tot. Rad. Pwr. (dBm)	4.6	3.6	7.2
Peak EIRP (dBm)	9.6	7.3	9.8
Peak ERP (dBm)	7.5	5.1	7.7
Directivity (dBi)	5.0	3.7	2.6
Efficiency 14dBm (dB)	-9.4	-10.4	-6.8
Efficiency 14dBm (%)	11.6	9.2	20.7
Gain 14dBm (dBi)	-4.4	-6.7	-4.2
NHPRP $\pm\pi/4$ (dBm)	3.4	2.3	5.9
NHPRP $\pm\pi/6$ (dBm)	2.1	0.9	4.5
Boresight Phi ($^{\circ}$)	240.0	165.0	225.0
Boresight Th. ($^{\circ}$)	135.0	90.0	135.0

Tab. 14: Summary Tx measurement results at 869.525 MHz.

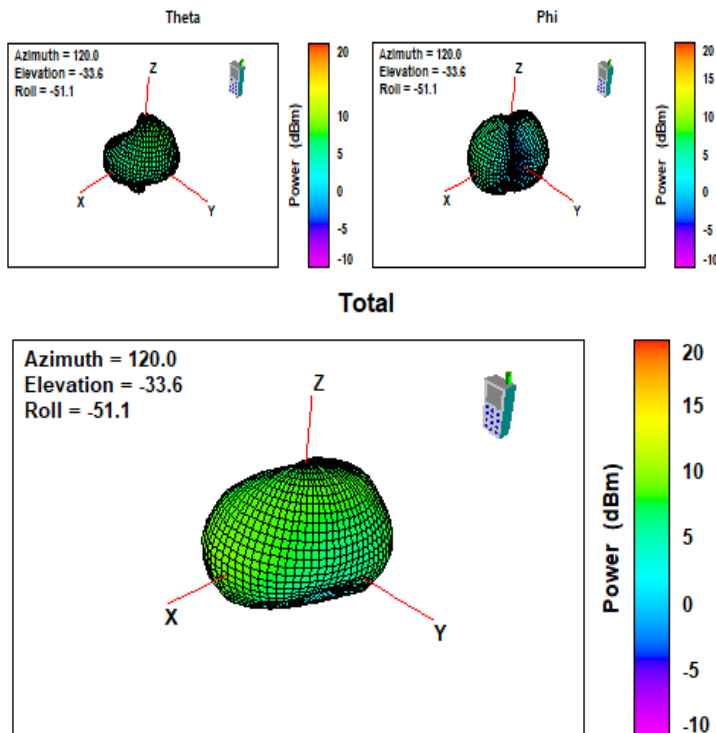

Fig. 15: 3D Pattern at 869.525 MHz.

Th 90° Phi (°)	FSP reading (dBm)	path loss (dB)	EIRP (dBm)	FSP reading (dBm)	path loss (dB)	EIRP (dBm)	EIRP (dBm)
	Polarisation Theta			Polarisation Phi			Total
360	-29.4	35.1	5.7	-29.6	35.7	6.1	8.9
345	-29.4	35.1	5.7	-29.0	35.7	6.7	9.3
330	-29.4	35.1	5.7	-29.1	35.7	6.6	9.2
315	-29.4	35.1	5.7	-29.9	35.7	5.8	8.8
300	-29.4	35.1	5.7	-31.3	35.7	4.4	8.1
285	-29.5	35.1	5.6	-33.6	35.7	2.1	7.2
270	-29.5	35.1	5.6	-37.7	35.7	-2.0	6.3
255	-29.5	35.1	5.6	-45.5	35.7	-9.8	5.7
240	-29.4	35.1	5.7	-43.2	35.7	-7.5	5.9
225	-29.4	35.1	5.7	-36.4	35.7	-0.6	6.6
210	-29.4	35.1	5.7	-32.6	35.7	3.1	7.6
195	-29.4	35.1	5.7	-30.3	35.7	5.4	8.6
180	-29.4	35.1	5.7	-29.0	35.7	6.7	9.2
165	-29.5	35.1	5.6	-28.4	35.7	7.3	9.5
150	-29.7	35.1	5.4	-28.5	35.7	7.2	9.4
135	-29.8	35.1	5.3	-29.1	35.7	6.6	9.0
120	-30.0	35.1	5.1	-30.4	35.7	5.3	8.2
105	-30.1	35.1	5.0	-32.4	35.7	3.3	7.2
90	-30.1	35.1	5.0	-35.6	35.7	0.1	6.2
75	-30.1	35.1	5.0	-39.5	35.7	-3.8	5.5
60	-30.0	35.1	5.1	-40.0	35.7	-4.3	5.6
45	-29.8	35.1	5.3	-36.1	35.7	-0.4	6.3
30	-29.7	35.1	5.4	-32.9	35.7	2.8	7.3
15	-29.5	35.1	5.6	-30.9	35.7	4.8	8.2
0	-29.4	35.1	5.7	-29.6	35.7	6.1	8.9

Tab. 15: Summary measurement results EIRP at 869.525 MHz X-Y plane.

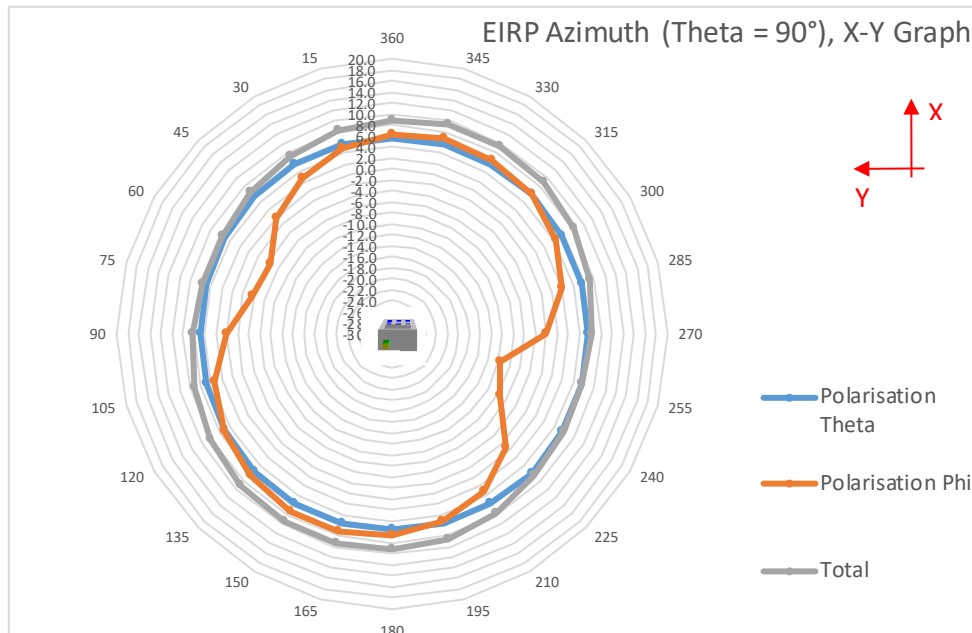

Fig. 16: 2D Pattern, X-Y plant at 869.525 MHz.

Phi = 0°	FSP reading (dBm)	path loss (dB)	EIRP (dBm)	FSP reading (dBm)	path loss (dB)	EIRP (dBm)	EIRP (dBm)
Theta	Pol Theta			Polarisation Phi			Total
0	-37.2	35.1	-2.1	-30.9	35.7	4.8	5.6
15	-32.9	35.1	2.2	-30.7	35.7	5.1	6.8
30	-30.8	35.1	4.3	-30.2	35.7	5.5	7.9
45	-30.1	35.1	5.0	-29.8	35.7	6.0	8.5
60	-29.7	35.1	5.3	-29.6	35.7	6.1	8.8
75	-29.1	35.1	6.0	-29.6	35.7	6.1	9.0
90	-29.4	35.1	5.7	-29.6	35.7	6.1	8.9
105	-30.9	35.1	4.2	-29.9	35.7	5.8	8.1
120	-33.7	35.1	1.4	-30.0	35.7	5.7	7.1
135	-38.3	35.1	-3.3	-30.8	35.7	4.9	5.5
150	-44.4	35.1	-9.3	-31.4	35.7	4.3	4.5
165	-44.2	35.1	-9.2	-30.9	35.7	4.8	5.0
180	-44.3	35.1	-9.2	-29.7	35.7	6.1	6.2
195	-33.1	35.1	2.0	-30.7	35.7	5.0	6.8
210	-29.9	35.1	5.2	-31.0	35.7	4.7	8.0
225	-28.4	35.1	6.7	-29.9	35.7	5.8	9.3
240	-28.1	35.1	7.0	-29.4	35.7	6.3	9.7
255	-28.5	35.1	6.6	-29.3	35.7	6.5	9.5
270	-29.4	35.1	5.7	-29.0	35.7	6.7	9.2
285	-32.2	35.1	2.9	-29.2	35.7	6.5	8.1
300	-35.6	35.1	-0.5	-30.0	35.7	5.7	6.7
315	-38.8	35.1	-3.8	-29.7	35.7	6.1	6.5
330	-46.5	35.1	-11.4	-29.8	35.7	5.9	6.0
345	-40.3	35.1	-5.2	-29.9	35.7	5.8	6.1
360	-37.2	35.1	-2.1	-30.9	35.7	4.8	5.6

Tab. 16: Summary measurement results EIRP at 869.525 MHz Z-X plane.

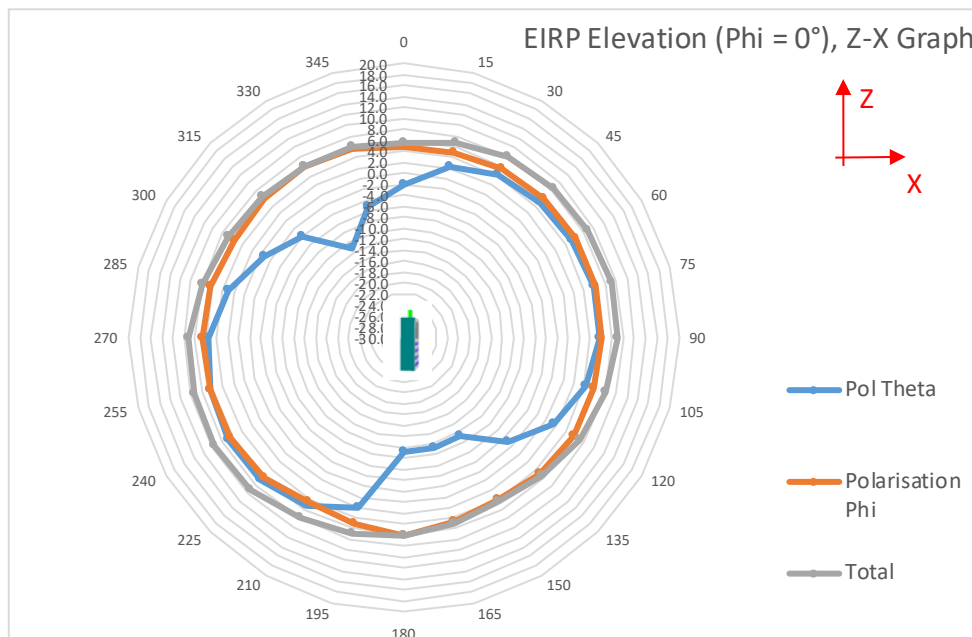

Fig. 17: 2D Pattern, Z-X plant at 869.525 MHz.

Phi 90° Theta	FSP reading (dBm)	path loss (dB)	EIRP (dBm)	FSP reading (dBm)	path loss (dB)	EIRP (dBm)	EIRP (dBm)
	Polarisation Theta			Polarisation Phi			Total
0	-30.3	35.1	4.8	-37.8	35.7	-2.1	5.6
15	-28.1	35.1	7.0	-37.0	35.7	-1.3	7.6
30	-27.4	35.1	7.7	-36.0	35.7	-0.3	8.3
45	-27.7	35.1	7.4	-36.3	35.7	-0.6	8.0
60	-28.8	35.1	6.3	-36.4	35.7	-0.7	7.1
75	-29.1	35.1	5.9	-37.7	35.7	-2.0	6.6
90	-30.1	35.1	5.0	-35.6	35.7	0.1	6.2
105	-32.3	35.1	2.8	-36.3	35.7	-0.6	4.4
120	-37.1	35.1	-2.0	-35.5	35.7	0.3	2.3
135	-48.6	35.1	-13.6	-36.5	35.7	-0.8	-0.5
150	-40.9	35.1	-5.8	-36.1	35.7	-0.4	0.7
165	-33.4	35.1	1.7	-37.0	35.7	-1.2	3.5
180	-29.0	35.1	6.1	-44.9	35.7	-9.2	6.2
195	-28.0	35.1	7.1	-37.0	35.7	-1.3	7.7
210	-27.0	35.1	8.1	-36.9	35.7	-1.2	8.6
225	-26.0	35.1	9.1	-38.9	35.7	-3.2	9.4
240	-26.7	35.1	8.4	-37.5	35.7	-1.8	8.8
255	-27.8	35.1	7.3	-38.4	35.7	-2.7	7.7
270	-29.5	35.1	5.6	-37.7	35.7	-2.0	6.3
285	-33.4	35.1	1.7	-38.6	35.7	-2.9	3.0
300	-38.6	35.1	-3.5	-37.0	35.7	-1.3	0.7
315	-58.5	35.1	-23.4	-38.6	35.7	-2.9	-2.8
330	-38.4	35.1	-3.4	-38.4	35.7	-2.6	0.0
345	-31.9	35.1	3.2	-39.3	35.7	-3.6	4.0
360	-30.3	35.1	4.8	-37.8	35.7	-2.1	5.6

Tab. 17: Summary measurement results EIRP at 869.525 MHz Z-Y plane.

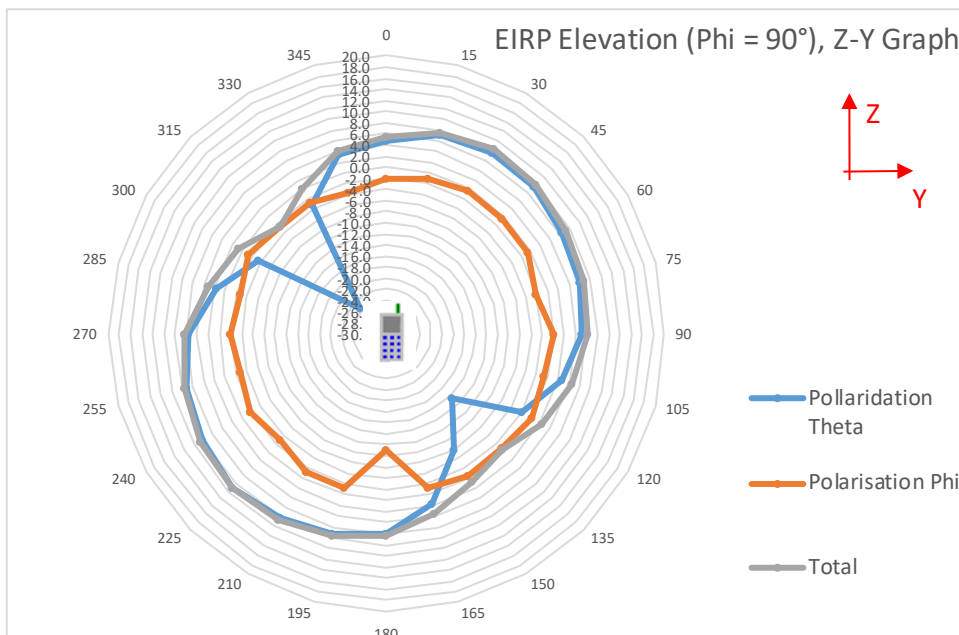

Fig. 18: 2D Pattern, Z-Y plant at 869.525 MHz.

4.5 End-device transmitter performance EIRP at different carrier powers

Tx Power	EIRP (dBm) @ MaxEIRP carrier p	863.1 MHz	865.1 MHz	868.3 MHz	869.525 MHz
Positon	Theta	135.0	135.0	135.0	135.0
	Phi	240.0	225.0	225.0	225.0
	Polarisaton	Total	Total	Total	Total
	Peak EIRP (dBm)	11.6	11.2	10.1	9.8
	Peak ERP (dBm)	9.4	9.0	7.9	7.7
Tx Power	EIRP (dBm) @ MaxEIRP - 6 dB carrier power				
Positon	Theta	135.0	135.0	135.0	
	Phi	225.0	225.0	225.0	
	Polarisaton	Total	Total	Total	
	Peak EIRP (dBm)	9.2	8.5	6.9	
	Peak ERP (dBm)	7.1	6.3	4.8	
Tx Power	EIRP (dBm) @ MaxEIRP - 12 dB carrier power				
Positon	Theta	135.0	135.0	135.0	
	Phi	225.0	225.0	225.0	
	Polarisaton	Total	Total	Total	
	Peak EIRP (dBm)	2.8	2.2	0.9	
	Peak ERP (dBm)	0.6	0.0	-1.3	

Tab. 18: Summary measurement results EIRP at different carrier powers.

4.6 End-device receiver performance EIS, 868.3 MHz, Rx1, Datarate SF12

End-device receiver performance	Result	Reference (according to chapter 3.2)
EIS(ϕ_0, θ_0)	-133.6	(1)
EIS (dB)	-133.8	(3)
TIS Tot. Rad. Sensitivity. (dBm)	-131.1	(4)
Boresight Phi ($^\circ$), ϕ_0	240.0	Chosen Phi Direction
Boresight Th. ($^\circ$), θ_0	135.0	Chosen Theta Direction
Boresight Polarisation	Theta	Chosen Polarisation
RF step-attenuator attenuation (dB)	67.9	Step attenuator (10 % PER)
NSA (including Lcable and Gref) (path loss dB)	35.1	(2)
Gateway Tx power (dBm)	10.6	Measured value

Tab. 19: Summary measurement results EIS, 868.3 MHz, Rx1, Datarate SF12.

4.7 End-device receiver performance EIS, 865.1 MHz, Rx1, Datarate SF12

End-device receiver performance	Result	Reference (according to chapter 3.2)
EIS(ϕ_0, θ_0)	-132.0	(1)
EIS (dB)	-132.1	(3)
TIS Tot. Rad. Sensitivity. (dBm)	-129.0	(4)
Boresight Phi ($^\circ$), ϕ_0	240.0	Chosen Phi Direction
Boresight Th. ($^\circ$), θ_0	135.0	Chosen Theta Direction
Boresight Polarisation	Theta	Chosen Polarisation
RF step-attenuator attenuation (dB)	64.0	Step attenuator (10 % PER)
NSA (including Lcable and Gref) (path loss dB)	35.5	(2)
Gateway Tx power (dBm)	8.7	Measured value

Tab. 20: Summary measurement results EIS, 865.1 MHz, Rx1, Datarate SF12.

4.8 End-device receiver performance EIS, 863.1 MHz, Rx1, Datarate SF12

End-device receiver performance	Result	Reference (according to chapter 3.2)
EIS(ϕ_0, θ_0)	-133.7	(1)
EIS (dB)	-133.8	(3)
TIS Tot. Rad. Sensitivity. (dBm)	-130.5	(4)
Boresight Phi ($^\circ$), ϕ_0	240.0	Chosen Phi Direction
Boresight Th. ($^\circ$), θ_0	135.0	Chosen Theta Direction
Boresight Polarisation	Theta	Chosen Polarisation
RF step-attenuator attenuation (dB)	49.3	Step attenuator (10 % PER)
NSA (including Lcable and Gref) (path loss dB)	35.7	(2)
Gateway Tx power (dBm)	-7.5	Measured value

Tab. 21: Summary measurement results EIS, 863.1 MHz, Rx1, Datarate SF12.

4.9 End-device receiver performance EIS, 869.525 MHz, Rx2, Datarate SF12

End-device receiver performance	Result	Reference (according to chapter 3.2)
EIS(ϕ_0, θ_0)	-133.4	(1)
EIS (dB)	-133.6	(3)
TIS Tot. Rad. Sensitivity. (dBm)	-130.9	(4)
Boresight Phi ($^\circ$), ϕ_0	240.0	Chosen Phi Direction
Boresight Th. ($^\circ$), θ_0	135.0	Chosen Theta Direction
Boresight Polarisation	Theta	Chosen Polarisation
RF step-attenuator attenuation (dB)	68.1	Step attenuator (10 % PER)
NSA (including Lcable and Gref) (path loss dB)	35.1	(2)
Gateway Tx power (dBm)	11.0	Measured value

Tab. 22: Summary measurement results EIS, 869.525 MHz, Rx2, Datarate SF12.

4.10 End-device receiver performance EIS, 869.525 MHz, Rx2, Datarate SF7

End-device receiver performance	Result	Reference (according to chapter 3.2)
EIS(ϕ_0, θ_0)	-121.1	(1)
EIS (dB)	-121.3	(3)
TIS Tot. Rad. Sensitivity. (dBm)	-118.6	(4)
Boresight Phi ($^\circ$), ϕ_0	240.0	Chosen Phi Direction
Boresight Th. ($^\circ$), θ_0	135.0	Chosen Theta Direction
Boresight Polarisation	Theta	Chosen Polarisation
RF step-attenuator attenuation (dB)	0.0	Step attenuator (10 % PER)
NSA (including Lcable and Gref) (path loss dB)	-86.8	(2)
Gateway Tx power (dBm)	11.0	Measured value

Tab. 23: Summary measurement results EIS, 869.525 MHz, Rx2, Datarate SF7.