



UC51x Series

LoRaWAN® Solenoid Valve Controller

User Guide

Contents

Chapter 1. Preface.....	4
Chapter 2. Product Introduction.....	6
Overview.....	6
Packing List.....	6
Hardware Components.....	7
Main Components.....	7
Power Button and LED Indicator.....	9
Device Dimensions.....	10
Chapter 3. ToolBox App Configuration.....	12
Access the Device Using NFC.....	12
Synchronize Device Time.....	14
Configure LoRaWAN® Parameters.....	15
Configure the Joining Type and the Frequency.....	15
Configure Basic Network Parameters.....	18
Configure the Mulesight D2D Parameters (UC511 Only).....	21
Configure Multicast Groups.....	23
Configure the Device Parameters.....	29
Change the Device Password.....	29
Configure Basic Device Parameters	30
Configure the Data Storage & Retransmission.....	32
Control the Solenoid Valve.....	35
Configure the GPIO Port.....	36
Configure the Rule Engine.....	39
Maintain the Device.....	43
Upgrade the Device.....	43
Configure a Template for Configuration Backup.....	45
Reset the Device.....	47

Chapter 4. Hardware Installation.....	49
Install the External Antenna (External Antenna Version Only).....	49
Install the Back Cover.....	49
Install the Device.....	50
Chapter 5. Uplink Packets and Downlink Commands.....	52
Uplink Packets.....	52
Device Information Packet.....	52
Periodically Reported Data Packet.....	53
Alarm Packet.....	54
Downlink Commands.....	56
Commands for General Setting.....	56
Commands for Work Mode Switching.....	57
Commands for Valve Setting.....	59
Commands for GPIO Setting.....	63
Commands for D2D Setting.....	64
Commands for Rule Setting.....	65
Historical Data Query Commands.....	75
Chapter 6. Services.....	78

Chapter 1. Preface

Copyright Statement

This guide may not be reproduced in any form or by any means to create any derivative such as translation, transformation, or adaptation without the prior written permission of Xiamen Milesight IoT Co., Ltd (Hereinafter referred to as Milesight).

Milesight reserves the right to change this guide and the specifications without prior notice. The latest specifications and user documentation for all Milesight products are available on our official website <http://www.milesight.com>

Safety Instruction

These instructions are intended to ensure that user can use the product correctly to avoid danger or property loss. Milesight will not shoulder responsibility for any loss or damage resulting from not following the instructions of this operating guide.



CAUTION:

Injury or equipment damage may be caused if any of these cautions are neglected.

- Do not disassemble or remodel the device in any way.
- Do not expose the device to open flames.
- Do not operate the device outside its specified temperature range.
- Power off the device during installing or wiring.
- Take care to prevent electronic components from loosening or falling out when opening the enclosure.
- Do not subject the device to shock or impact.

Revision History

Release Date	Version	Revision Content
Feb. 29, 2024	V 4.0	Initial version on hardware 4.x

Release Date	Version	Revision Content
Jan. 8, 2025	V 4.1	<ol style="list-style-type: none">1. Add DI status definition feature2. Update UI of ToolBox App3. Remove ToolBox software configuration
Nov. 21, 2025	V 4.2	<ol style="list-style-type: none">1. Remove the feature of data storage, data retransmission and retrievability2. Support timed switching of the LoRaWAN® work mode via downlink command3. Add a new valve control command for rain special control4. Support FUOTA feature5. Optimized the upgrade speed, support iOS upgrade via ToolBox App

Chapter 2. Product Introduction

This chapter describes basic product information.

Overview

UC51x series LoRaWAN[®] Solenoid Valve Controller is a device used to remotely control DC latching solenoids of the valve. It contains 2 solenoid interfaces and 2 GPIO interfaces, which can be easily controlled locally or remotely.

Besides ultra-low-power LoRaWAN[®] technology, UC51x series also provides a built-in solar panel and high-capacity battery power supply for long-term operation. For outdoor applications, it equips with an IP68-rated enclosure and M12 connectors, providing protection against water and dust under harsh environments.

UC51x series is widely used for agriculture valves, landscape irrigation systems, garden irrigation systems, etc.

The device has the following features:

- Compatible with standard DC latching solenoids
- Waterproof design including IP68 case and M12 connectors
- Solar-powered and built-in chargeable batteries
- OPEN/CLOSE control by mobile App locally or commands remotely
- Support multiple local rules allows for flexible control without network
- Two GPIO interfaces for flow monitoring or valve status monitoring
- Transmission distance up to 15 km with line of sight
- Support Mulesight D2D protocol to enable ultra-low latency and direct control without gateways
- Equipped with NFC for easy configuration
- Time and flow control via Mulesight IoT Cloud or Mulesight Development Platform
- Support multicast for control in bulk
- Supports timed switching of work modes for easier device deployment and maintenance
- Support Firmware Upgrade Over the Air (FUOTA) feature

Packing List

This chapter describes the packing list. You can verify the contents against the following list to ensure all items are present. If any of them is missing or damaged, you can contact your sales representative.

Universal Accessories

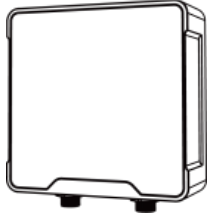

1 × UC51x Device



2 × Data Cables (1.5m)

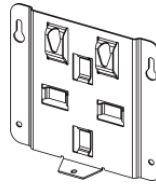

1 × Mounting Bracket



4 × Wall Mounting Kits



2 × Hose Clamps



1 × Fixing Screw



1 × Quick Guide



1 × Warranty Card

Accessories Exclusively for External Antenna Version



1 × LoRaWAN®
Magnetic Antenna

Accessories Exclusively for UC511 External Antenna Version (Optional)



1 × Power Cable (50cm)

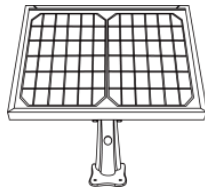

1 × Solar Panel Kit

Hardware Components

Main Components

The following figure shows the main components of the device.

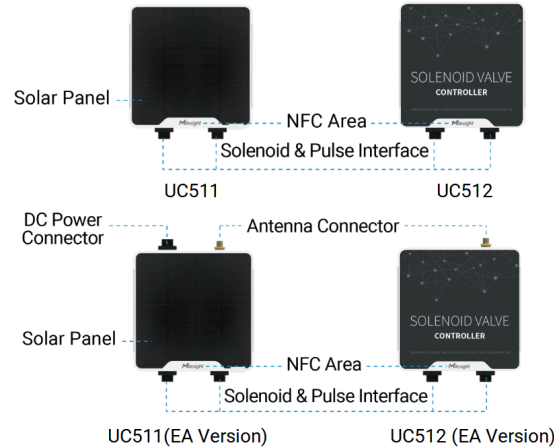

For the description of each component, refer to the following table.

Name	Description
NFC area	Allows for wireless configuration through mobile phone NFC.
Solenoid&Pulse interface	Connects to the valve and flow sensor, enabling precise control and real-time monitoring of water volume.
Antenna	External antenna version allows for the attachment of an external antenna to enhance wireless communication range and reliability. The non-external antenna version features an integrated antenna.
Solar panel (UC511 Only)	<p>Powers the device, enabling extended operation without relying on external power sources.</p> <div style="background-color: #e0f2f1; padding: 10px; border-radius: 5px;"> <p>i Tip: Clean the solar panel surface on schedule or according to local environmental conditions. The solar panel may be affected by environmental factors such as dust, sand, and bird droppings, which can reduce their charge efficiency.</p> </div>
DC power connector (UC511 External Antenna version Only)	Powers the device and supports battery charging.

For the description of interfaces, refer to the following tables.

Table 1. Solenoid & Pulse Interface Description

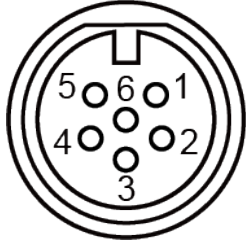
Pin	Description	Figure
1	DC+/OUT1 of Solenoid Valve	
2	DC-/OUT2 of Solenoid Valve	
3	GND	
4	INSERT BOOT, see Wiring Switch option	
5	GND	
6	GPIO Interface	



CAUTION:

Prevent wires from touching during use to avoid device damage. Insulate unused wires with tape.

Table 2. DC Power Connector Description (UC511-EA)

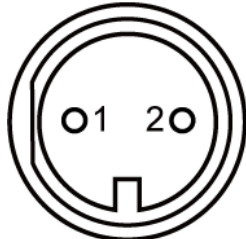
Pin	Description	Figure
1	VCC(5-24V)	
2	GND	

Power Button and LED Indicator

The device has an internal power button and an LED indicator for emergency reboot and reset functions. For the functions of the power button and the corresponding LED indicator status, refer to the following table.

Function	Action	LED Indication
Turn On	Press and hold the button for more than 3s.	Off → On
Turn Off		On → Off
Reset	Press and hold the button for more than 10s.	Blinks.
Check On/Off Status	Quickly press the power button once.	Light On: Device is on.
		Light Off: Device is off.

Device Dimensions

The following figure shows the device dimensions (unit: mm).

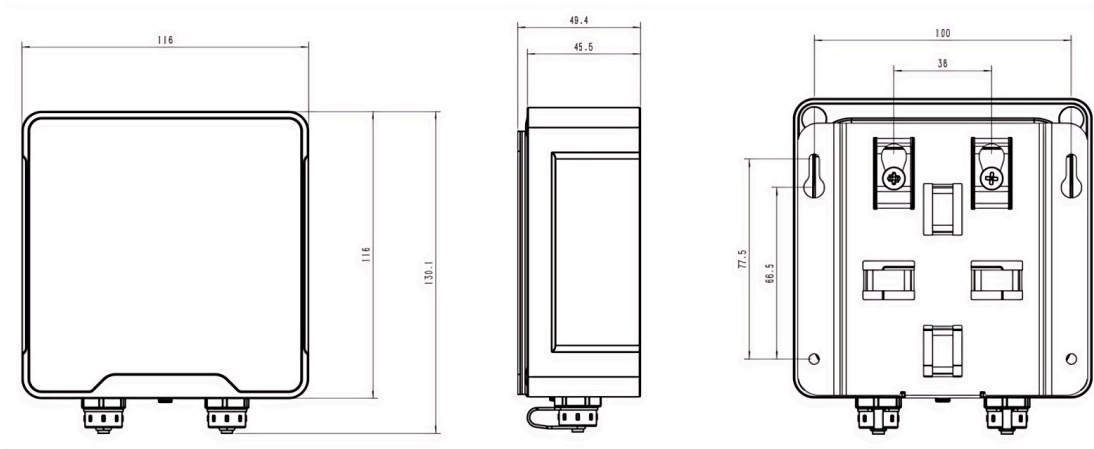

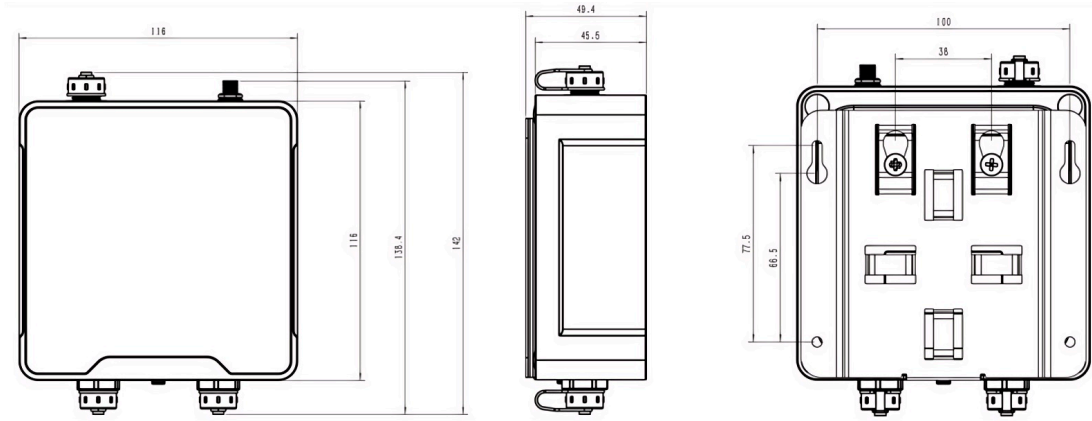

Chapter 3. ToolBox App Configuration

The device can be configured through Milesight ToolBox App on a mobile phone. This chapter describes related configuration on ToolBox App.

Access the Device Using NFC

The device can be monitored and configured using NFC. This section describes how to access the device using NFC.

Steps:

1. Download Milesight ToolBox app from Google Play or Apple Store.
2. Enable the NFC function on the smart phone.
3. Launch ToolBox.
 - a. Upon first launch, the following page is displayed. Select **NFC** and click **Enter**.

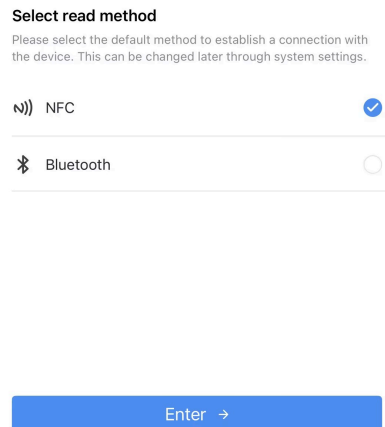

b. Upon subsequent launches, Click **Maintenance** on the home page, and then select **NFC**.

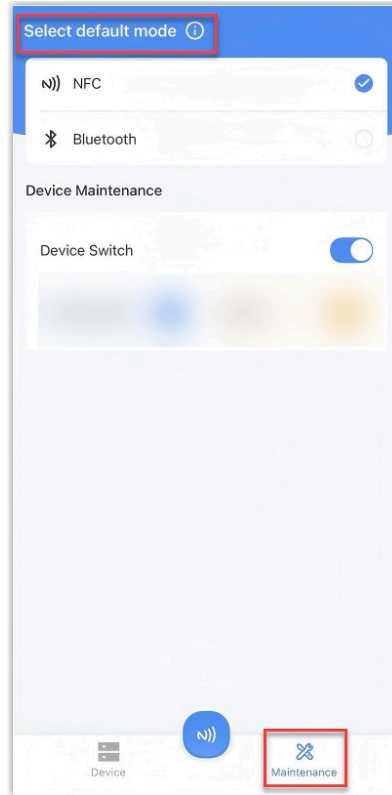

4. (Optional) To locate the NFC detection areas of the phone and the device, click **Can't find the NFC location**.

5. Put the NFC detection area of the phone close to the NFC area of the device.





Tip:

It is recommended to take off the phone case.

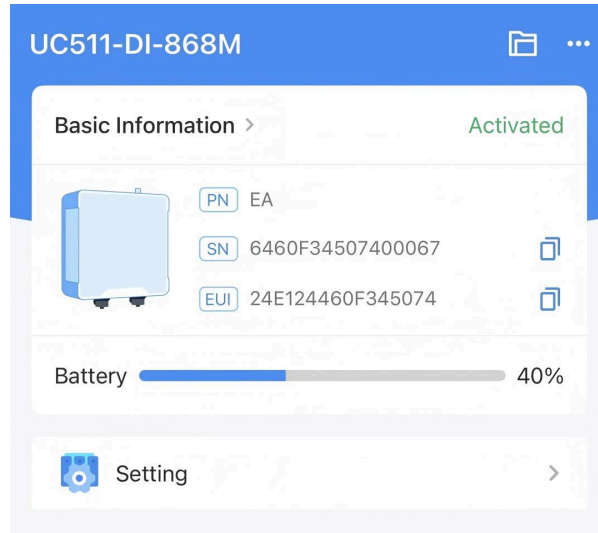

- Click . If the device is recognized successfully, the homepage is displayed. For a description of the homepage, refer to the following table. If read fails, move the phone away and reposition it close to the device to try again.



Item	Description
Basic Information	Shows basic device information, powers off the device, and sync the system time.
Setting	Sets the device and network parameters.
	Imports, adds, exports or deletes a template.
	Sets the language and shows NFC positions.

Synchronize Device Time

This section describes how to sync the device time.

Synchronize the Time Manually Through ToolBox

- On the homepage of ToolBox, click **Basic Information**.
- Click  to synchronize the time.

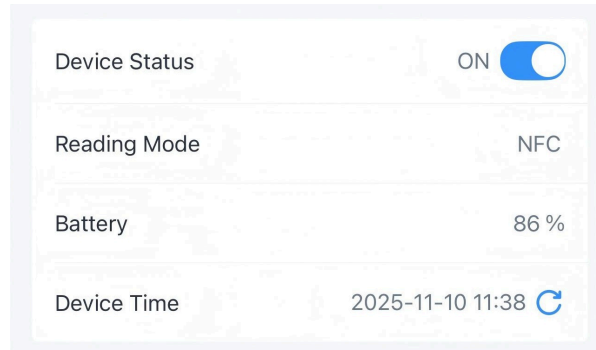

3. Put the NFC detection area of the phone close to the NFC antenna of the device. If the time is synchronized successfully, the following page is displayed.



Sync successfully!

Synchronize the Time Automatically Through a LoRaWAN[®] Network Server

Prerequisite: The LoRaWAN[®] network server supports the device time synchronization feature.

1. Set the LoRaWAN[®] version of the device to **V1.0.3**. For details, refer to [Configure Basic Network Parameters](#).
2. Connect the device to the network server. For details, refer to [Connect the Device to a Network Server](#). Once the device successfully joins the network, it sends a MAC command to query the time from the network server.

Configure LoRaWAN[®] Parameters

This section describes how to configure the device transmission parameters for the LoRaWAN[®] network. Among them, the joining type and the frequency must be configured. Otherwise, the device cannot join the network.

Configure the Joining Type and the Frequency

This section describes how to configure the joining type and the frequency.

Steps:

1. On the homepage of ToolBox, click **Setting** to enter the **Setting** page.
2. Click **Network**. The **Network** page is displayed, see the following figure.

The screenshot shows the 'Network' configuration page. At the top, there are two tabs: 'Device' and 'Network'. Below the tabs, there are two sub-sections: 'LoRaWAN' and 'D2D'. The 'LoRaWAN' section is active and contains the following fields:

- Device EUI: 24E124460F345074
- APP EUI: 24e124c0002a0001
- * Application Port: 85
- LoRaWAN Version: V1.0.3
- Work Mode: Class C
- Confirmed Mode:

The 'D2D' section is visible below a horizontal separator and contains:

- Join Type: OTAA
- Buttons: Read, Write

3. From the **Join Type** selection box, select **OTAA** or **ABP** as needed.

**Note:**

OTAA is required if you connect the device to the [Milesight IoT Cloud Platform](#) or [Milesight Development Platform](#).

4. Configure **Join Type** related parameters as needed. Use default values unless otherwise specified.

- If **OTAA** is selected, configure **Application Key** and **Rejoin Mode** as needed. For details, refer to the following table.

Parameter	Description
Application Key	<p>Appkey for OTAA mode. Default: Device EUI + Device EUI (since Q4 of 2025).</p> <p>Example: 24e124123456789024e1241234567890. Default value of earlier devices: 5572404C696E6B4C6F52613230313823.</p> <div style="background-color: #e6f2ff; padding: 10px; border-radius: 5px;"> <p> Tip: Contact sales before purchase if you need random App keys.</p> </div>
Rejoin Mode	<p>Rejoin mode for OTAA mode.</p> <p>Reporting interval ≤ 35 minutes: The device sends a specific number of LinkCheckReq MAC packets at each reporting interval or at every other reporting interval to validate connectivity.</p> <p>Reporting interval > 35 minutes: The device sends a specific number of LinkCheckReq MAC packets at each reporting interval to validate connectivity.</p> <p>If there is no response, the device will re-join the network.</p> <p>When Rejoin Mode is enabled, enter a number in the Set the number of detection signals sent text box. The actual sending number is the configured number +1.</p>

- If **ABP** is selected, configure **Network Session Key**, **Application Session Key** and **Device Address** as needed. For details, refer to the following table.

Parameter	Description
Network Session Key	<p>Nwkskey for ABP mode. Default: 5572404C696E6B4C6F52613230313823.</p>

Parameter	Description
Application Session Key	Appskey for ABP mode. Default: 5572404C696E6B4C6F52613230313823.
Device Address	DevAddr for ABP mode. Default: 5 th to 12 th digits of SN.

5. Select a frequency from the **Support Frequency** selection box as needed. The frequency must be the same as that of the gateway configured on the gateway web GUI.
6. If **CN470**, **US915** or **AU915** is selected, enter the index of the channel that you want to enable in the **Enable Channel Index** input box. The channel indexes should be separated by commas.

Examples:

- 1, 40: Enables channel 1 and channel 40
- 1-40: Enables channel 1 to channel 40
- 1-40, 60: Enables channel 1 to channel 40 and channel 60
- Null: Indicates that all channels are disabled

7. Click **Write** and put the NFC detection area of the phone close to the NFC antenna of device. If the configuration succeeds, the following page is displayed.



Write successfully!

Configure Basic Network Parameters

This section describes how to configure the LoRaWAN[®] parameters of the device. You can use default values unless otherwise specified.



Steps:

1. On the homepage of ToolBox, click **Setting** to enter the **Setting** page.
2. Click **Network**. The **Network** page is displayed, see the following figure.

The screenshot shows the 'Network' configuration page. At the top, there are two tabs: 'Device' and 'Network', with 'Network' selected. Below the tabs, there are two main sections: 'LoRaWAN' and 'D2D'. Under 'LoRaWAN', there are two sub-sections: 'D2D' (indicated by a blue underline) and 'D2D'. The 'D2D' section contains the following fields: 'Device EUI' with the value '24E124460F345074', 'APP EUI' with the value '24e124c0002a0001', '* Application Port' with the value '85', 'LoRaWAN Version' set to 'V1.0.3', 'Work Mode' set to 'Class C', and 'Confirmed Mode' which is a toggle switch currently turned on. Below the 'D2D' section, there is a 'Join Type' dropdown menu set to 'OTAA'. At the bottom of the page, there are two buttons: 'Read' and 'Write'.

3. Configure the following parameter as needed. Use default values unless otherwise specified. For a description of the parameters, refer to the following table.

Parameter	Description
Device EUI	Unique ID of the device labelled on the device housing.

Parameter	Description
	<p> Tip: For bulk deployments, contact sales to request the device EUI list.</p>
App EUI	The default App EUI (join EUI) is 24E124C0002A0001.
Application Port	The port used for sending and receiving data, the default port is 85.
LoRaWAN [®] Version	V1.0.2 and V1.0.3 are available.
Work Mode	<p>Options for UC511: Class A, Class B, Class C and Class C to B.</p> <p>Options for UC512: Class A and Class B.</p> <p> Tip:</p> <ol style="list-style-type: none"> Class A targets maximum battery life. Class B caters to scheduled command reception. If the device does not receive beacons for more than 120 minutes, it will switch to Class A mode automatically. Class C enables real-time, low-latency communication. Class C to B balances real-time needs with power savings. If the device does not receive beacons for more than 30 minutes, it will switch to Class C mode automatically.
Confirmed Mode	If the device does not receive ACK packet from network server, it will re-send data once.
Join Type	Refer to Configure the Joining Type and the Frequency .
Supported Frequency	Refer to Configure the Joining Type and the Frequency .
ADR Mode	Enable or disable network server to adjust Spreading Factor, Bandwidth and Tx Power to optimize data rates, airtime and energy consumption in the network.
Spreading Factor	If ADR mode is disabled, the device sends uplink data using this spreading factor. A higher spreading factor increases transmission range but

Parameter	Description
	reduces data rate and increases power consumption. This parameter varies with Supported Frequency .
Tx Power	Defined by the LoRa Alliance. Specifies the strength of the radio signal transmitted by the device.
RX2 Data Rate	Data rate for receiving downlinks or Milesight D2D commands on the RX2 window.
RX2 Frequency	Frequency for receiving downlink or Milesight D2D commands on the RX2 window. Unit: Hz.
Ping Slot Periodicity	When the class type is Class B or Class C to B, the device will open the reception window according to this period.

4. Click **Write** and put the NFC detection area of the phone close to the NFC antenna of device. If the configuration succeeds, the following page is displayed.



Write successfully!

Configure the Milesight D2D Parameters (UC511 Only)

Milesight D2D protocol is developed by Milesight and used for setting up transmission among Milesight devices without gateway. When the Milesight D2D settings is enabled, the device can work as a Milesight D2D agent to receive commands to control the solenoid valve status. This section describes how to configure the D2D parameters.

Steps:

1. On the homepage of ToolBox, click **Setting** to enter the **Setting** page.
2. Click **Network**. Set the **Work Mode** as **Class C**.
3. Configure the **RX2 Data Rate** and **RX2 Frequency** to be the same as the settings of Milesight D2D controller.



Tip:

It is suggested to change the default values if there are many LoRaWAN[®] devices around.

Device Network

LoRaWAN D2D

Spreading Factor ⓘ
SF12-DR0

TXPower
TXPower0-16 dBm

RX2 Data Rate ⓘ
DR0 (SF12, 125 kHz)

RX2 Frequency ⓘ
869525000

4. Click **D2D**. Enable Milesight D2D feature and define a unique D2D key that is the same as Milesight D2D controller. (Default D2D key: 5572404C696E6B4C6F52613230313823).

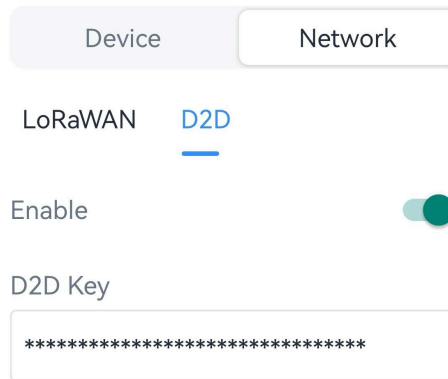

5. Set rule to work as a Milesight D2D agent. Refer to [Configure the Rule Engine](#).
6. Click **Write** and put the NFC detection area of the phone close to the NFC antenna of device. If the configuration succeeds, the following page is displayed.



Write successfully!

Configure Multicast Groups

UC51x supports the configuration of multiple multicast groups. This enables batch control of devices by receiving commands from network servers. This section describes how to configure multicast groups.

Create a Multicast Group on ToolBox

This section describes how to create a multicast group on ToolBox.

Steps:

1. On the homepage of ToolBox, click **Setting** to enter the **Setting** page.
2. Click **Network**. The **Network** page is displayed, see the following figure.

Device Network

LoRaWAN D2D

Device EUI

24E124460F345074

APP EUI

24e124c0002a0001

* Application Port

85

LoRaWAN Version

V1.0.3

Work Mode

Class C

Confirmed Mode ⓘ

Join Type

OTAA

Read Write

3. Set the work mode to **Class C**, **Class B** or **Class C to B**. The following page is displayed at the bottom.

Multicast Group1

Multicast Address ⓘ

McNetSKey

McAppSKey

Multicast Ping Slot Periodicity/s

Multicast Data Rate

Multicast Frequency

Multicast Group2

Multicast Group3

Multicast Group4

4. Set multicast address and keys as described in the following table. Use default values unless otherwise specified.

Parameter	Description
Multicast Address	Unique address to distinguish multicast groups. Type: hexadecimal, length: 8 characters.
McNetSKey	32-digit key. Default values: - Multicast Group 1: 5572404C696E6B4C6F52613230313823 - Multicast Group 2: 5572404C696E6B4C6F52613230313824 - Multicast Group 3: 5572404C696E6B4C6F52613230313825 - Multicast Group 4: 5572404C696E6B4C6F52613230313826
McAppSKey	32-digit key. Default values: - Multicast Group 1: 5572404C696E6B4C6F52613230313823 - Multicast Group 2: 5572404C696E6B4C6F52613230313824 - Multicast Group 3: 5572404C696E6B4C6F52613230313825 - Multicast Group 4: 5572404C696E6B4C6F52613230313826
Multicast Ping Slot Periodicity/s	The device will open the reception window according to this period to receive multicast commands.
Multicast Data Rate	The data rate to receive multicast commands. Unit: Hz
Multicast Frequency	The frequency to receive multicast commands. Unit: Hz

5. (Optional) To configure another multicast group, follow steps 4 to 5 to configure the corresponding group.

6. Click **Write** and put the NFC detection area of the phone close to the NFC antenna of device. If the configuration succeeds, the following page is displayed.



Write successfully!

Add a Multicast group on the Network Server

This section describes how to add a multicast group on the network server. A Milesight gateway is taken as an example for description.

Steps:

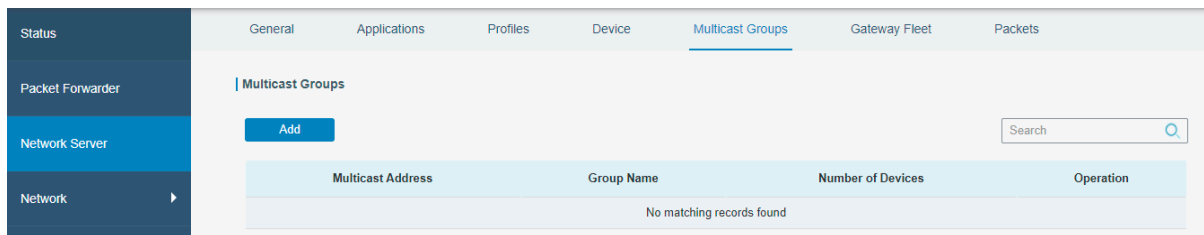

1. On the gateway web GUI, click **Network Server > Multicast Groups**. The **Multicast Groups** page is displayed.



2. Click **Add** to add a multicast group.
3. Enter the multicast group parameters to match those configured on ToolBox and select the devices that you need to control.

Group Name	Valve Control
Multicast Address	11111111
Multicast Network Session Key	5572404C696E6B4C6F526132
Multicast Application Session Key	5572404C696E6B4C6F526132
Class Type	Class C
Datarate	DR0 (SF12, 125 kHz)
Frequency	505300000 Hz
Frame-counter	0
Selected Devices	
<div style="border: 1px solid #ccc; padding: 5px;"> UC51X x </div>	

4. Click **Save**. The multicast group is listed in the **Multicast Groups** page.

Multicast Address	Group Name	Number of Devices	Operation
11111111	Valve Control	1	 

5. Click **Packets** in the upper right corner. The **Packets** page is displayed.

6. Select the multicast group from the **Multicast Groups** drop-down list.

7. Enter a downlink command in the **Payload** text box.

8. Click **Send**. The network server broadcasts the command to all devices in this multicast group. The application ports of all devices must be the same.

The screenshot shows the 'Packets' configuration page in the ToolBox App. The left sidebar contains navigation options: Status, Packet Forwarder, Network Server (selected), Protocol Integration, Network, System, and Maintenance. The main content area has tabs for General, Applications, Payload Codec, Profiles, Device, Multicast Groups, Gateway Fleet, and Packets. Under the 'Send Data to Device' section, there is a table with columns: Device EUI, Type, Payload, Port, and Confirmed. Below this, the 'Send Data to Multicast Group' section is highlighted with a red box. It contains a table with columns: Multicast Group, Type, Payload, and Port. The 'Valve Control' multicast group is selected with a 'hex' type and a payload of 'ff1d2100'. The port is set to 85. A 'Send' button is visible at the end of the row.

Configure the Device Parameters

This section describes how to configure the device.

Change the Device Password

It is recommended to change the device password upon initial configuration for security purposes. This section describes how to change the password.

Steps:

1. On the homepage, click **Setting** to enter the **Setting** page.
2. In the **General** page, enable **Change Password**.
3. In the **New Password** text box, enter a new password. Password length: 6 characters.
4. In the **Confirm Password** text box, enter the password again.
5. Click **Write** and put the NFC detection area of the phone close to the NFC antenna of device. If the password was changed successfully, the following page is displayed.



Write successfully!



Configure Basic Device Parameters

This section describes how to configure the basic parameters of the device, which includes:



- Reporting interval
- Data Storage
- Data Retransmission
- Auto-Confirmed Mechanism
- Wiring Switch
- Data Reporting
- When Power is Restored
- Working Mode
- Response Time

Steps:

1. On the homepage, click **Setting** to enter the **Setting** page.
2. In the **General** page, configure the following device parameters as needed.

Parameter	Description
Reporting Interval	Reporting interval for transmitting data to the network server. Default: 360 mins, range: 1-1080 mins.
Data Storage	<div style="background-color: #fff9c4; padding: 5px; border: 1px solid #ccc;">  Important: This feature is only supported in versions prior to V1.4. </div> <p>Disables or enables reporting data storage locally. For details, refer to Configure the Data Storage&Retransmission.</p>
Data Retransmission	<div style="background-color: #fff9c4; padding: 5px; border: 1px solid #ccc;">  Important: This feature is only supported in versions prior to V1.4. </div> <p>Disables or enables data retransmission. For details, refer to Configure the Data Storage&Retransmission.</p>
Auto-Confirmed Mechanism	When Auto-Confirmed Mechanism is enabled:

Parameter	Description
	<ul style="list-style-type: none"> ◦ If Confirmed Mode in NS is also enabled, the device will respond with an ACK containing a packet starting with "FE". ◦ If Confirmed Mode in NS is disabled, the device will send a packet starting with "FE". <p>When Auto-Confirmed Mechanism is disabled:</p> <ul style="list-style-type: none"> ◦ If Confirmed Mode in NS is enabled, the device will respond with an empty ACK. ◦ If Confirmed Mode in NS is disabled, the device will not send any uplink acknowledgment.
Wiring Switch	When this option is enabled, the UC51x will turn on automatically when a data cable is connected to any solenoid interface.
Data Reporting	<p>Select the periodic packet report content.</p> <p>Options: All, Interface 1 Only, and Interface 2 Only.</p>
When Power is Restored	<p>This parameter configures the device to either automatically restart or remain off when power is restored after an outage.</p> <p>Options: Last Working Status, Device On, Valve Off, and Device On, Valve ON.</p>
Working Mode	<p>Working mode of LoRaWAN[®] device.</p> <p>Options for UC511: Class A, Class B, Class C and Class C to B.</p> <p>Options for UC512: Class A and Class B.</p> <div style="background-color: #e0f2f1; padding: 10px; border-radius: 5px;"> <p> Tip:</p> <ol style="list-style-type: none"> a. Class A targets maximum battery life. b. Class B caters to scheduled command reception. If the device does not receive beacons for more than 120 minutes, it will switch to Class A mode automatically. c. Class C enables real-time, low-latency communication. </div>

Parameter	Description
	<p> d. Class C to B balances real-time needs with power savings. If the device does not receive beacons for more than 30 minutes, it will switch to Class C mode automatically.</p>
Response Time	<p>When the class type is Class A: the device will send a blank packet to allow to receive the control commands at every Response Time interval. Range: 0-64800s, 0 means disabled.</p> <p>When the class type is Class B or Class C to B: the device will open the reception window according to the response time interval.</p> <p> Tip: The shorter the response time, the shorter the battery life.</p>
Change Password	Refer to Change the Device Password .

3. Click **Write** in the lower right corner.
4. Put the NFC detection area of the phone close to the NFC antenna of device. If the configuration succeeds, the following page is displayed.



Write successfully!

Configure the Data Storage & Retransmission

 **Important:**

This feature is only supported in versions prior to V1.4.

UC51x series supports data storage, data retransmission and historical data queries to ensure data integrity. Data retransmission allows the network server receives all data, even after temporary network outages. This section describes how to configure data storage and retransmission.

Export the Local Data

Steps:

1. [Sync the time](#) to ensure the data is stored in correct time.
2. On the homepage of ToolBox, click **Setting** to enter the **Setting** page.
3. Enable **Data Storage**.
4. Return to the homepage and click **Maintenance** in the lower right corner.
5. Click **Export**, select the data time range and click **Save** to export data.



Note:

- ToolBox App can only export the last 14 days' data at most.
- The device will still store the data even the network status is de-activated.

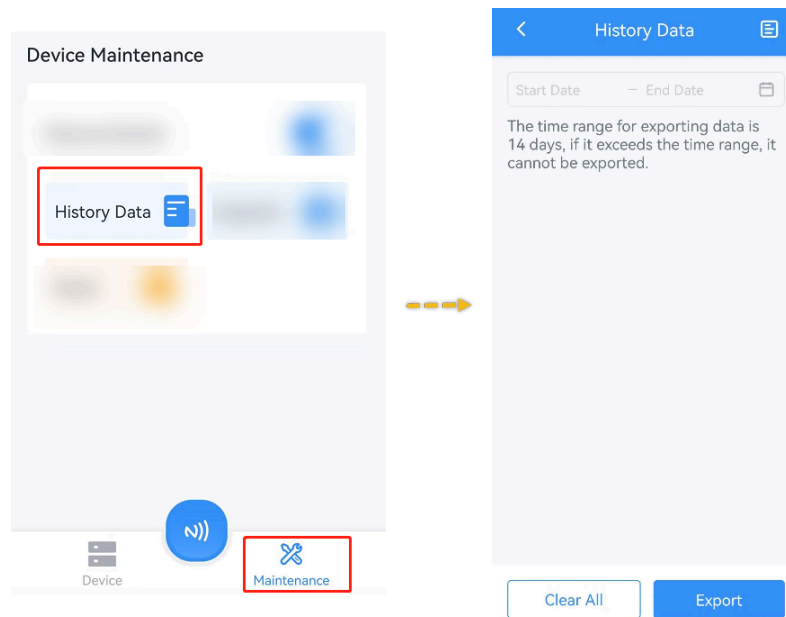

Enable Data Retransmission

Steps:

1. On the homepage, click **Setting** to enter the **Setting** page.
2. Enable **Data Storage** and **Data Retransmission**.
3. Click **Network** to enter the **Network** page.
4. Set Join Type to **OTAA**, enable **Rejoin Mode** and set the number of packets sent.
5. Click **Write** and put the NFC detection area of the phone close to the NFC antenna of device. If the configuration succeeds, the following page is displayed.



Write successfully!



Note:

1. Data retransmission increases the uplink traffic and shortens the battery life.
2. If the device reboots or loses power during data retransmission, it restarts and resends the entire retransmission dataset after reconnecting to the network.
3. If a new network disconnection occurs during an ongoing retransmission, only the data logged during this latest outage will be sent upon reconnection.
4. The default report data retransmission interval is 600s, this can be changed via downlink command.

Query Historical Data

UC51x series supports querying historical data for a specific time range via downlink command. The retransmission data format includes timestamps and differs from the periodic report format. For details, refer to [Historical Data Query Commands](#).

Control the Solenoid Valve

UC51x series supports to control the solenoid valve via ToolBox locally. Besides, this can also be executed via downlink commands or local rules. This section describes how to control the solenoid valve locally.

Steps:

1. On the homepage of ToolBox, see **Valve1** and **Valve2** in **Detection Status**.
2. Click **Off/On** to turn on/off the valve as need.

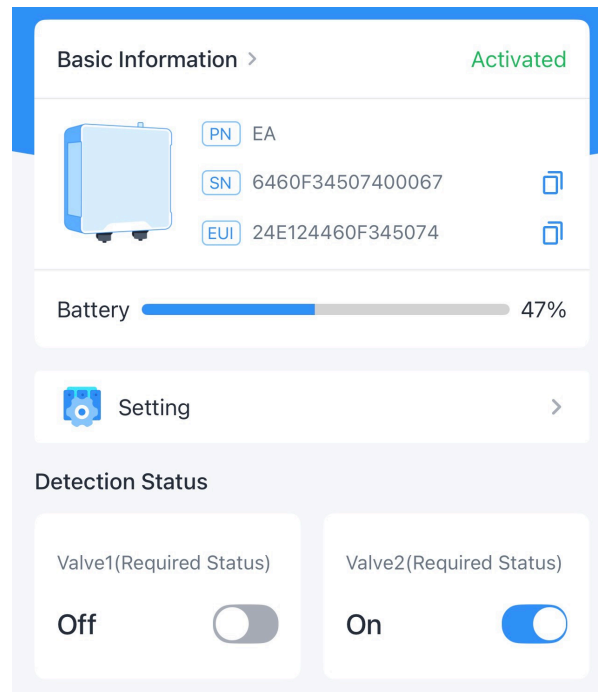

3. Put the NFC detection area of the phone close to the NFC antenna of device. If the configuration succeeds, the following page is displayed.



Write successfully!

Configure the GPIO Port

This section describes how to configure the GPIO ports.

Steps:

1. Connect devices to GPIO ports on interface.
2. On the homepage of ToolBox, click **Setting** to enter the **Setting** page.
3. Click **GPIO**. The following page is displayed.

The screenshot shows the 'Setting' page with the 'Device' tab selected. The 'GPIO' sub-tab is active. The configuration for GPIO1 and GPIO2 is as follows:

- GPIO1 Working Mode:** Digital Input
- DI Status Definition:**
 - Open Valve: High
 - Close Valve: Low
- GPIO2 Working Mode:** Digital Input
- DI Status Definition:**
 - Open Valve: High
 - Close Valve: Low

At the bottom of the page, there are two buttons: 'Read' and 'Write'.

4. Set **GPIO1/2 Working Mode** to **Digital input** or **Water Volume Counter** as needed.

Working Mode	Description
Digital Input	Detect the real state of the valve to know if valve control takes effect.
Water Volume Counter	Connect to pulse water meter to measure the water volume.

5. Perform any of the following operations as needed.

- If **GPIO1/2 Working Mode** is set to **Digital input**, configure the following parameters as needed.

GPIO1 Working Mode ⓘ

Digital Input ▼

DI Status Definition

Open Valve

High ▼

Close Valve

Low

Parameters	Description
DI Status Definition	Set the Open Valve of Low/High status. The device will report the DI status according to this definition.
Prevent Jitter Delay Time (s)	The device will not upload GPIO status during this time to avoid frequent uplinks. This only works when GPIO working mode is Digital Input and this applies to both GPIO interfaces.

- If **GPIO1/2 Working Mode** is set to **Water Volume Counter**, configure the following parameters as needed.

GPIO2 Working Mode

Water Volume Counter ▼

Counter 2

0 Confirm

Pulse Filter Setting ⓘ

250 US ▼

Parameters	Description
Counter	Set the initial counting value and click Confirm to save this value. Reboot or re-join will not affect the counting. The pulse value supports to clear manually via ToolBox or downlink command, or clear automatically when it calculates to max value: 4294967295 (0xffffffff).
Pulse Filter Setting	Filter the pulse counting values below this rate. This only works when GPIO working mode is Water Volume Counter and this applies to both GPIO interfaces.

6. Click **Write** and put the NFC detection area of the phone close to the NFC antenna of device. If the configuration succeeds, the following page is displayed.



Write successfully!

Configure the Rule Engine

UC51x support multiple local rules allows for flexible control without network. Each device supports a maximum of 16 rules. This section describes how to configure rule.

Steps:

1. On the homepage of ToolBox, click **Setting** to enter the **Setting** page.
2. Click **Rule Engine** and  Continue adding .
3. Set rule to **Time, Water volume, Every increases of water volume** and **D2D** as needed.
 - If rule is set to **Time**, refer to [Time Sync](#) to ensure the device time is correct, then configure the related parameters as needed.

Example: During the time range 2025-11-10 8:00 to 2025-12-10 8:00, open the valve 1 at 0:00 for 5 minutes every 5 days.

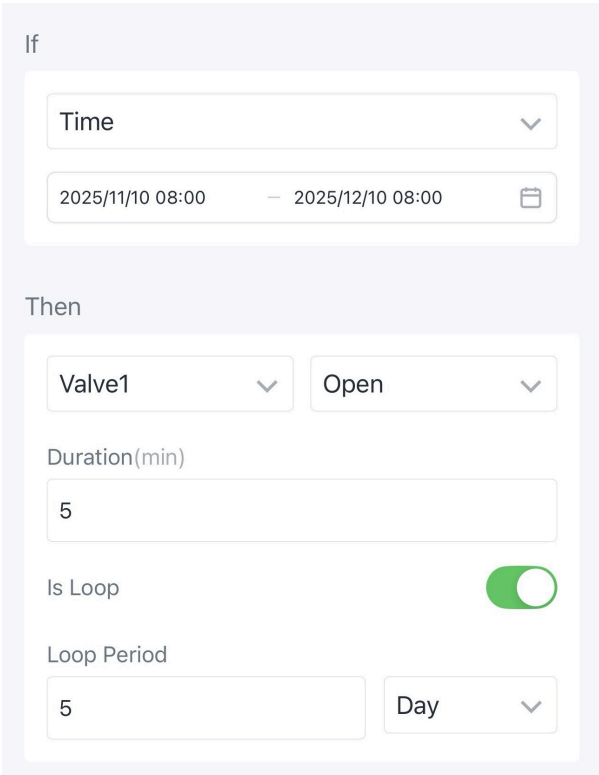

The screenshot shows the configuration interface for a rule. It is divided into two main sections: 'If' and 'Then'.

If section:

- A dropdown menu is set to 'Time'.
- A date range is specified as '2025/11/10 08:00' to '2025/12/10 08:00'.

Then section:

- A dropdown menu is set to 'Valve1'.
- A dropdown menu is set to 'Open'.
- The 'Duration(min)' field is set to '5'.
- The 'Is Loop' toggle switch is turned on (green).
- The 'Loop Period' field is set to '5'.
- A dropdown menu for the loop period is set to 'Day'.

- If rule is set to **Water volume**, configure the related parameters as needed.

Example: When the GPIO2 detects 20 pulses within 2 minutes, the device will report a status packet to network server, the max length of custom message is 8 characters.

If

Water Volume

Water Volume Counter 2

Period(min)

2

Threshold(Pulses)

20

Then

Report counter value and valve status

- If rule is set to **Every increases of water volume**, configure the related parameters as needed.

Example: Every time the counter of GPIO2 increases 20, the device will report a custom message to the network server, the max length of custom message is 8 characters.

If

Every increase of water volume

Water Volume Counter 2

Threshold(Pulses)

20

Then

Report customized message

Message

alarm

- If rule is set to **D2D**, configure the related parameters as needed.



Note:

D2D rule has higher execute priority than other types of rules.

Example: When the device receives Milesight D2D command ff01, it can open solenoid valve1 for 5 minutes.

4. Click **Save** to save the configuration.
5. Enable or disable the rules as required in **Rule Engine** page. When the device has multiple rules that are conflicted, the device will execute the rule with front **Rule ID** in priority.

6. To modify the rule configuration, click **Edit**.
7. (Optional) Click **Export Template** to back up the rule settings into the smartphone; if you need to import the rule settings from other devices, click **Import Template** to import the setting.

8. Click **Write** and put the NFC detection area of the phone close to the NFC antenna of device. If the configuration succeeds, the following page is displayed.



Write successfully!

Maintain the Device

This section describes how to maintain the device.

Upgrade the Device

Steps:

1. Download firmware from [Milesight official website](#) and save it to the smart phone.
2. Launch ToolBox and click **Maintenance** in the lower right corner of the homepage.
3. Click **Upgrade** to import firmware and upgrade the device.
4. Click **Upgrade** and put the NFC detection area of the phone close to the NFC antenna of the device.

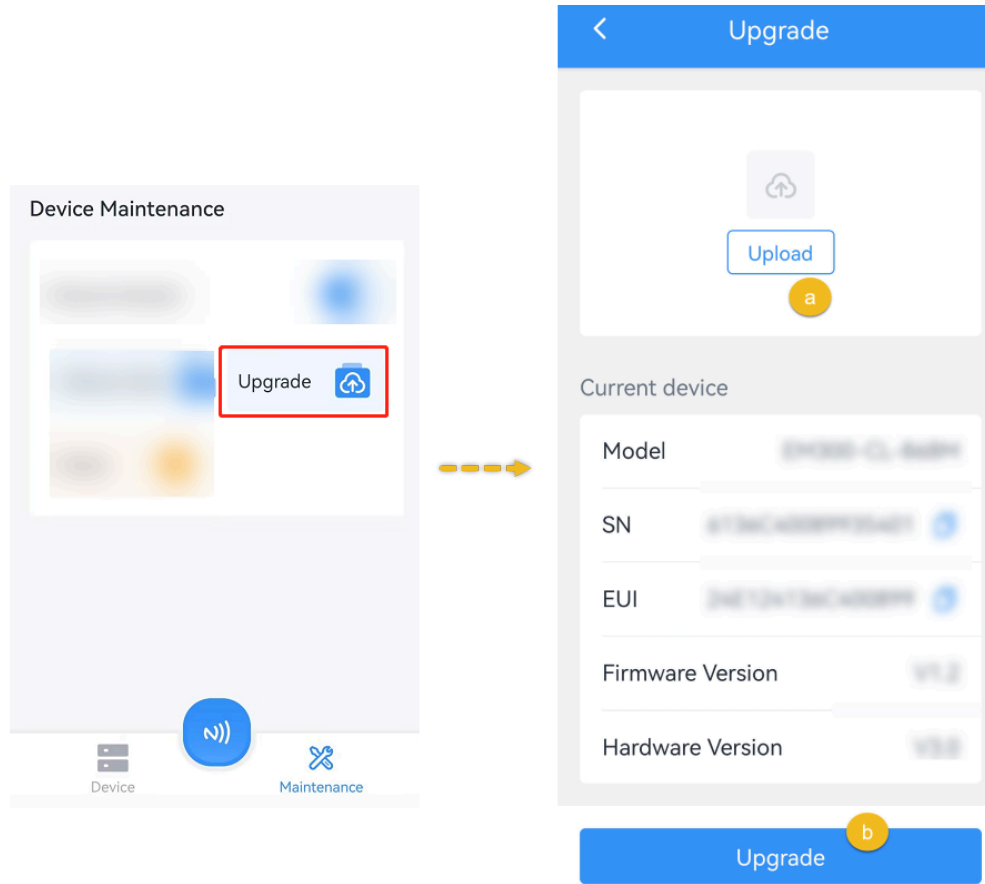

5. If the configuration succeeds, the following page is displayed.



Write successfully!



Note:

Any operation on ToolBox is not allowed during upgrading, otherwise the upgrading will be interrupted, or even the device will break down.

Configure a Template for Configuration Backup

This device supports configuration backup, which enables quick and easy batch configuration. This function only applies for devices of the same model and LoRaWAN[®] frequency band.



Note:

The backup file will not save rule setting, please refer to [Configure the Rule Engine](#) backup rule settings.

Set a Template

Steps:

1. On the homepage of ToolBox, click . The **Template** page is displayed.
2. Click **Add Template** in the bottom.
3. Click **Save** in the upper right corner. The **Template Name** page is displayed.

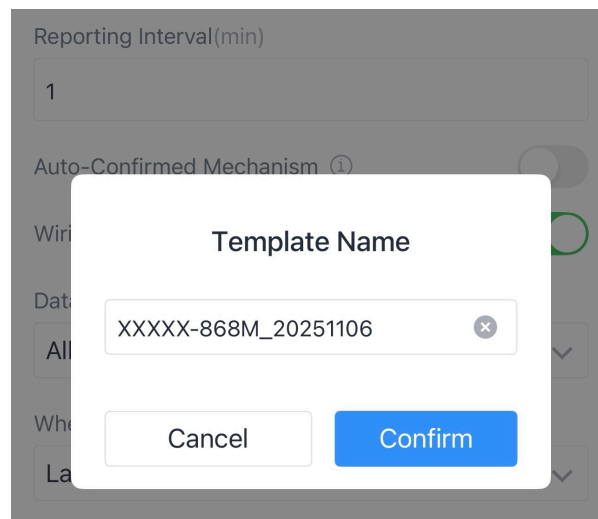

4. Click **Confirm** to save the current configuration as a template. The following page is displayed.

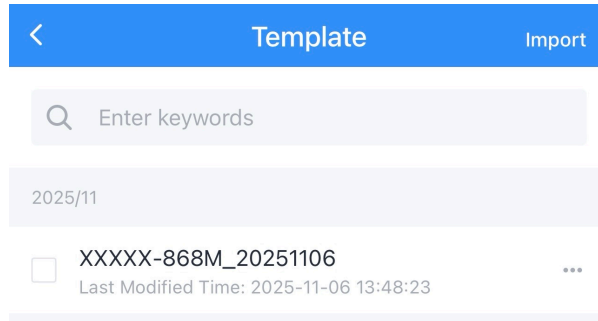

Write the template configuration to the target device

Steps:

1. Click the saved template. Caution: Do not select the template.

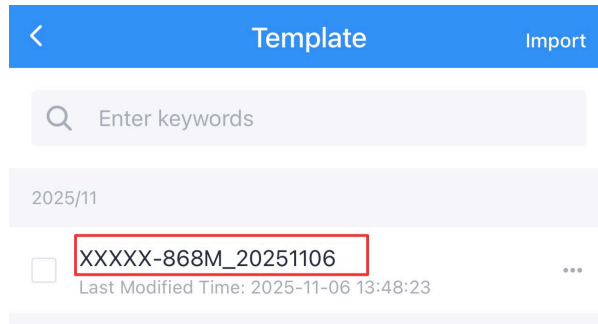

2. In the displayed page, click **Write** in the bottom and put the NFC detection area of the phone close to the NFC antenna of the target device. If the configuration is written to the target device, the following page is displayed.



Write successfully!

Export and Delete a Template

1. Select the checkbox of the target template as shown in the following figure.

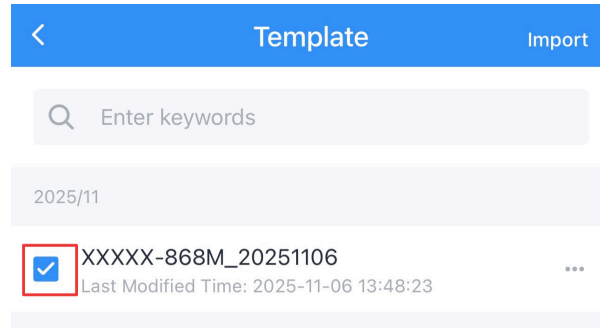

2. Click **Export** to export this template as a JSON format file and save it to the smart phone.
3. Click **Delete** and Confirm to delete this template from ToolBox.

Reset the Device

This section describes how to reset the device in ToolBox. Additionally, the device supports hardware reset. See [Power Button and LED Indicator](#) for details.

Steps:

1. On the homepage of ToolBox, click **Maintenance** in the lower right corner. The **Maintenance** page is displayed, see the following figure.

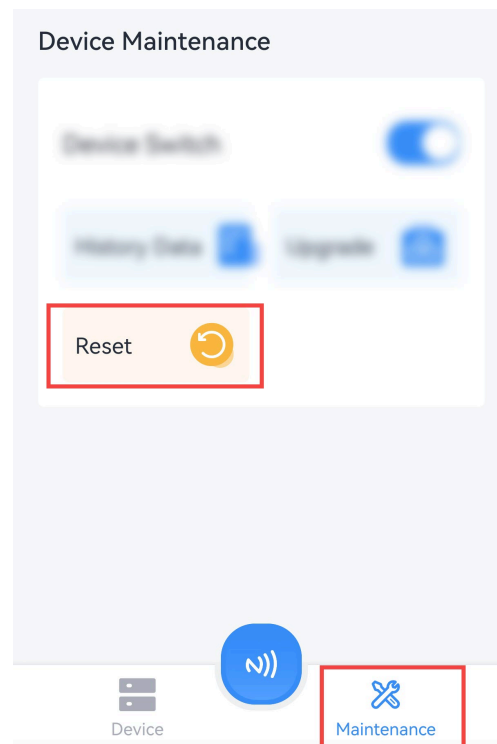

2. Click **Reset**.
3. In the displayed dialog box, click **Confirm**.
4. Put the NFC detection area of the phone close to the NFC antenna of the device. If the device is successfully reset, the following page is displayed.



Write successfully!

Chapter 4. Hardware Installation

This section describes how to install the external antenna, the back cover and the device.

Install the External Antenna (External Antenna Version Only)

This chapter describes how to install the external antenna.

To ensure optimal signal performance, adhere to the following guidelines when deploying the antenna:

1. Orient the antenna vertically and secure its magnetic base to a metal surface.
2. Position the antenna away from walls and other obstructions. For indoor use, installation near a window is recommended.
3. Maintain a minimum separation of 50 cm between multiple antennas.
4. For superior coverage, install the antenna at the highest practical point.

Steps:

1. Rotate the antenna into the antenna connector.

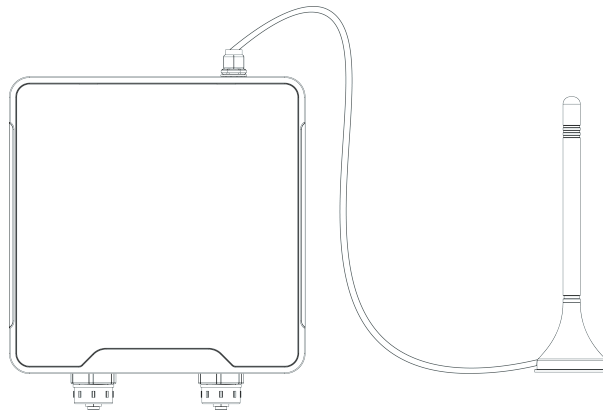

Install the Back Cover

This section describes how to install the back cover to ensure device waterproofing.

Steps:

1. Verify that the sealing ring is properly installed around the device, free from stains or foreign matters.
2. Orient the cover correctly and place it on the device.
3. Hand-tighten the four screws in a crisscross pattern to ensure even pressure.



4. Using a torque screwdriver, initially tighten each screw to 80–90% of the final torque (4.5–5 kgf·cm).
5. Fully tighten all screws to the specified torque in the same crisscross sequence.
6. Install the screw caps onto the screws.

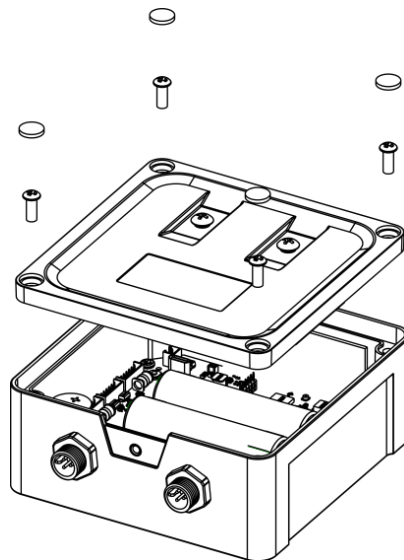

Install the Device

UC51x can be mounted on a wall or pole. This section describes how to install the device. Ensure the device is firmly fixed to the bracket. A loose connection can degrade signal quality.

Preparations: mounting bracket, wall or pole mounting kits

Wall Mounting:

Steps:

1. Insert the wall plugs into the wall.
2. Secure the mounting bracket to the wall plugs and fasten it with the screws.
3. Position the device on the mounting bracket.
4. Secure the bottom of the device to the bracket with the fixing screw.

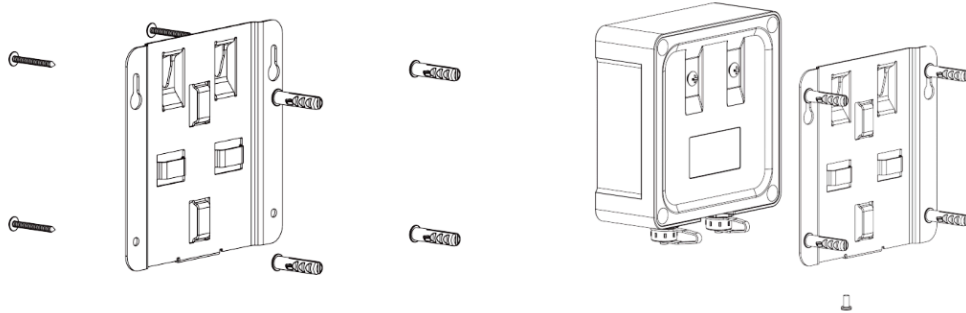

Pole Mounting

Steps:

1. Straighten the hose clamp and thread it through the rectangular rings on the mounting bracket.
2. Wrap the clamp securely around the pole.
3. Use a screwdriver to tighten the locking mechanism by turning it clockwise.
4. Position the device on the mounting bracket.
5. Secure the bottom of the device to the bracket with the fixing screw.

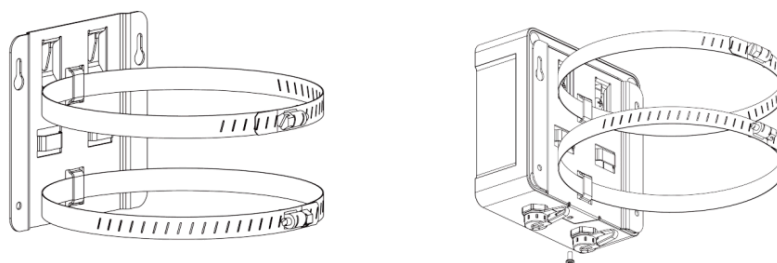

Chapter 5. Uplink Packets and Downlink Commands

The UC51x series uses the standard Milesight IoT payload format based on IPSO. This chapter describes the uplink data packets and downlink commands supported by the device. They are all structured in the following format, the Data field should follow **little endian**:

Channel 1	Type 1	Data 1	Channel 2	Type 2	Data 2	Channel 1	...
1 Byte	1 Byte	N Bytes	1 Byte	1 Byte	N Bytes	1 Byte	...

All explanations and examples in this document are based on the HEX format. For all the Milesight IoT decoder examples, refer to the files available on <https://github.com/Milesight-IoT/SensorDecoders>.

Uplink Packets

This section describes the uplink packets reported by the device. They can be checked on the gateway web GUI.

Device Information Packet

When joining the network, the device reports a packet containing the basic device information to the gateway.

Packet description:

Item	Channel	Type	Byte	Description
Power On	ff	0b	1	Device is on
Protocol Version	ff	01	1	Example: 01=V1
Hardware Version	ff	09	2	Example: 03 10 = V3.1
Software Version	ff	0a	2	Example: 03 01 = V3.1
Device Type	ff	0f	1	00: Class A, 01: Class B, 02: Class C, 03: Class C to B
Serial Number	ff	16	8	16 digits
TSL Version	ff	ff	2	Example: 01 00=>V1.0
Reset Event	ff	fe	1	ff, only report when the device resets

Example:

ff0bff ff0101 ffff0401 ff166415a51585070020 ff090100 ff0a0101 ff0f00		
Channel	Type	Value
ff	0b	Power On: ff
ff	01	Protocol Version: 01 = V1
ff	ff	TSL version: 0401 = V4.1
ff	16	Device SN: 6415a51585070020
ff	09	Hardware Version: 0100 = V1.0
ff	0a	Firmware Version: 0101 = V1.1
ff	0f	Device Type: 00: Class A

Periodically Reported Data Packet

The device reports a sensor data packet at a configured interval.

Packet description:

Item	Channel	Type	Byte	Description
Battery Level	01	75	1	UINT8, Unit: %
Valve 1	03	01	1	00 = closed, 01 = open
Counter 1 (GPIO1)	04	c8	4	UINT32
Valve 2	05	01	1	00 = closed, 01 = open
Counter 2 (GPIO2)	06	c8	4	UINT32
Digital Input (GPIO1)	07	01	1	00 = closed, 01 = open
Digital Input (GPIO2)	08	01	1	00 = closed, 01 = open

Example 1: The device reports its battery level upon initial network join and subsequently at intervals of 6 hours (UC511) or 12 hours (UC512).

01 75 5a		
Channel	Type	Value
01	75	Battery level: 5a => 90%

Example 2: The device reports a periodically packet at a configured interval (360min by default).

030101 04c84f000000 050100 080100		
Channel	Type	Value
03	01	Valve 1: 01 => Open
04	c8	Pulse counter of GPIO1: 4f 00 00 00 => 00 00 00 4f = 79
05	01	00 => Closed (Valve 2)
08	01	Digital input of GPIO2: 00 => Closed

Alarm Packet

UC51x series support to report the following several types of alarm packets.

Packet description:

Item	Channel	Type	Byte	Description
Battery Level	01	75	1	UINT8, Unit: %
Valve 1	03	01	1	00 = closed, 01 = open
Counter 1 (GPIO1)	04	c8	4	UINT32
Valve 2	05	01	1	00 = closed, 01 = open
Counter 2 (GPIO2)	06	c8	4	UINT32
Digital In- put (GPIO1)	07	01	1	00 = closed, 01 = open
Digital In- put (GPIO2)	08	01	1	00 = closed, 01 = open

Item	Channel	Type	Byte	Description
Custom Alarm Message	ff	12	1-8	ASCII characters

Example 1: Battery level alarm. Report once when the battery level drops to 1%.

01 75 01		
Channel	Type	Value
01	75	Battery level: 01 => 1%

Example 2: Valve status alarm. The device reports corresponding interface data when the valve status changes.

030101 04c84f000000		
Channel	Type	Value
03	01	Valve 1: 01 => Open
04	c8	Pulse counter of GPIO1: 4f 00 00 00 => 00 00 00 4f = 79

Example 3: Custom alarm message. Add a rule, every time the counter of GPIO2 increases 20, the device will report "alarm" to the network server.

If

Every increase of water volume ▼

Water Volume Counter 2 ▼

Threshold(Pulses)

20

Then

Report customized message ▼

Message

alarm

ff12 616c61726d		
Channel	Type	Value
ff	12	Hex to Ascii: 61 6c 61 72 6d=>=alarm

Downlink Commands

Downlink commands can be used for remote control of UC51x through a network server. The downlink port (application port) is 85 by default and can be configured through ToolBox.

Commands for General Setting

The device supports multiple commands for general setting.

Command description:

Item	Channel	Type	Byte	Description
Collect Interval	ff	02	2	UINT16, Unit: s
Report Interval	ff	03	2	UINT16, Unit: s
Reboot	ff	10	1	ff
UTC Time Zone	ff	17	2	INT16/10
Enquire Time from Server	ff	4a	1	ff <div style="border: 1px solid #ccc; background-color: #e6f2ff; padding: 5px; margin-top: 10px;">  Note: this only works when the LoRaWAN[®] version of device and server is 1.0.3 or later. </div>
Enquiry Current Data	ff	28	1	ff
Auto-confirmed Mechanism	ff	f3	1	00: disable, 01: enable
Response Time of Class A	ff	1e	4	UINT32, unit: s, range: 0-64800s

Example 1: Reboot the device.

ff10ff

Example 2: Set reporting interval as 20 minutes.

ff03b004		
Channel	Type	Value
ff	03	b004=>04b0=1200s=20 minutes

Example 3: Set the time zone as UTC-2.

ff17ecff		
Channel	Type	Value
ff	17	ecff=>ff ec=-20/10=-2

Commands for Work Mode Switching

The device supports command for timed switching of the LoRaWAN[®] work mode. This feature is suitable for water-saving system demonstration or device debugging.

Command description:

Channel	Type	Byte	Description
f9	a4	8	<p>Byte 1-4: start time, timestamp, unit: s</p> <p>Byte 5-6: duration, Unit: min, range: 1-1440</p> <p>Byte 7:</p> <ul style="list-style-type: none"> • 00: Class A • 01: Class B • 02: Class C • 03: Class C to B • ff: cancel <p>Byte 8: 00</p>

Channel	Type	Byte	Description
			 Note: If the duration is not specified or the start time is earlier than the current time, it will be treated as an immediate start.

Reply:

Channel	Type	Byte	Description
f8	4a	9	<p>Byte 1-8: same as issued</p> <p>Byte 9:</p> <ul style="list-style-type: none"> • 00: success • 01: invalid parameter • 02: start time is before the year 2000 and the time-stamp is not zero, invalid • 16: duration is 0, the device does not support • 17: duration is greater the maximum allowed • 18: instruction expired

Example: Starting from 2025-07-05 09:00:00, switches the working mode to Class C mode for a duration of 10 minutes.

f9a4 10796868 0a000200		
Channel	Type	Value
f9	a4	10796868 => 2025-07-05 09:00:00 0a 00 => 000a=10 mins 02: Class C

Reply:

f9a4 10796868 0a000200 00		
Channel	Type	Value
f8	a4	10796868 => 2025-07-05 09:00:00 0a 00 => 000a=10 mins 02: Class C 00: success

Commands for Valve Setting

The device supports command for valve setting.

Valve Control

This section describes how to control the valve.

Basic format 1 is used for time and flow control:

Channel	Type	Control Field (1B)	Sequence (1B)	Time Control (Option, 3B)	Flow Control (Option, 4B)
ff	1d	See Control format	Range: 1-255	Unit: s	Pulse counter

Control format:

Bit	Description
7	0: Disable time control, 1: Enable time control
6	0: Disable flow control, 1: Enable flow control
5	0: Valve close, 1: Valve open
4-2	000
1-0	00: Valve 1, 01: Valve 2

Basic format 2 is used for special control during rainy days:

Channel	Type	Control Field (1B)	Sequence (1B)	Time Control (Option, 3B)	Start Time (Option, 4B)
ff	1d	See Control format	Range: 1-255	Unit: min, Range: 0-1440	Timestamp, unit: s

Control format:

Bit	Description
7	0
6	0
5	0: Valve close, 1: Valve open
4-3	10: Enable rain special control , 01: Disable rain special control
2-0	000: Valve1, 001: Valve 2, 111: All valve



Note:

1. If you set the sequence as 01 to ff, the sequence number should be incremented each time it is used in one command sent to devices. For example, if you use command ff 1d 20 01 (sequence 01) to control the valve successfully, the next command should be ff 1d 20 02 (sequence 02). An incorrect sequence number will cause the command to be invalid.
2. If the sequence is up to ff (255), please restart the sequence from 01.
3. If the control command take effects, the device will report the status packet of corresponding interface; if control fails, the device will not report the packet.

Example 1: Open the valve 2 for 60s.

ff1d a1 02 3c0000				
Channel	Type	Control Field	Sequence	Time Control
ff	1d	a1 => 1010 0001 Bit 7: 1 => enable time control Bit 5: 1 => valve open Bit 0-2: 001 => valve 2	02	3c 00 00=>00 00 3c=60s

Example 2: Open the valve 1 until the 60s passes or pulse counter 1 increases 16 pulses.

ff1d e0 04 3c0000 1000000					
Channel	Type	Control Field	Sequence	Time Control	Flow Control
ff	1d	e0 => 1110 0000 Bit 7: 1 => enable time control Bit 6: 1 => enable flow control Bit 5: 1 => valve open Bit 0-2: 000 => valve 1	04	3c 00 00=>00 00 3c=60s	10 00 00 00 => 00 00 00 10 = 16

Example 3: Cancel the local rules scheduled by the device from 2025-10-23 10:50 to 2025-10-23 10:56.

ff1d 17 00 060000 d897f968					
Channel	Type	Control Field	Sequence	Time Control	Start Time
ff	1d	17=>0001 0111 Bit 5: 0 => valve close Bit 4-3: 10 => enable rain special control Bit 2-0: 111= all valve	00	06 00 00=>00 00 06=6 mins	d8 97 f9 68=> 2025-10-23 10:50

Enquire the Valve Status

Enquire format:

Channel	Type	Byte	Description
f9	a5	1	00: valve1, 01: valve2

Reply format:

Item	Channel	Type	Byte	Description
Enquire Result	f8	a5	2	<p>Byte 1:</p> <ul style="list-style-type: none"> • 00: valve1 • 01: valve2 <p>Byte 0:</p> <ul style="list-style-type: none"> • 00: success • 01: invalid parameter • 02: valve index out of range
Valve1 Task	0e	af	3	<p>Byte 1:</p> <ul style="list-style-type: none"> • 00: free • 01: local rule • 02: local rule with the highest execution priority • 03: rain special control • 04: time or flow control <p>Byte 2:</p> <ul style="list-style-type: none"> • 00 = valve closed • 01 = valve open <p>Byte 3:</p> <ul style="list-style-type: none"> • 00 = command on • 01 = command off
Valve2 Task	0f	af	3	<p>Byte 1:</p> <ul style="list-style-type: none"> • 00: free • 01: local rule • 02: local rule with the highest execution priority • 03: rain special control • 04: time or flow control

Item	Channel	Type	Byte	Description
				Byte 2: <ul style="list-style-type: none"> • 00 = valve closed • 01 = valve open Byte 3: <ul style="list-style-type: none"> • 00 = command on • 01 = command off

Example: Query the valve 1 task status.

f9 a5 00		
Channel	Type	Value
f9	a5	00: valve 1

Reply: Query success, the valve is under rain special control, valve 1 is closed, and the command is off.

f8 a5 00 00		
Channel	Type	Value
f8	a5	00: valve1 00: success

0e af 0300000		
Channel	Type	Value
0e	af	03: rain special control 00: valve1 close 00: command off

Commands for GPIO Setting

The device supports multiple commands for GPIO setting.

Command description:

Item	Channel	Type	Byte	Description
Counter Reset	ff	4e	2	GPIO 1 Counter: 0100, GPIO 2 Counter: 0200
Initial Value of Counter	ff	92	5	Byte 1: GPIO1=01, GPIO2=02 Byte 2-5: Initial Value, UINT32
Prevent Jitter Delay Time	ff	46	1	UINT8, unit:s
Pulse Filter	ff	52	4	Byte 1-2: 0002 Byte 3-4: Filter Time, UINT16, unit: ms

Example 1: Reset the counting value of GPIO1 when it works as pulse counter.

ff4e0100		
Channel	Type	Value
ff	4e	0100: counter 1

Example 2: Set the initial counting value of GPIO2 when it works as pulse counter.

ff920210000000		
Channel	Type	Value
ff	92	02=GPIO2 10 00 00 00=> 00 00 00 10=16

Commands for D2D Setting

The device supports multiple commands for D2D setting. About the D2D rule setting please refer to Rule Settings.

Command description:

Item	Channel	Type	Byte	Description
Milesight D2D Key	ff	35	4	First 16 digits, last 16 digits are fixed as 0
Milesight D2D	ff	84	1	00: disable, 01: enable

Example: Set Milesight D2D key as 12345678123456780000000000000000.

ff35 1234567812345678		
Channel	Type	Value
ff	35	12 34 56 78 12 34 56 78

Commands for Rule Setting

The device supports setting schedule plan to open or close valves at specific time.

Set the Rule

Basic format:

Channel	Type	Rule ID	Enable	Control Field (13B) + Action Field (13B)
ff	55	01~10(1~16)	00: disable 01: enable	Optional: Time , Receive D2D command , Water Volume , Every increase of water volume



Note:

1. D2D rule has higher execute priority than types of rules.
2. When the device has multiple rules that are conflicted, the device will execute the rule with front number ID in priority.

Condition: Time

Condition Field:

Byte	Description
1	01

Byte	Description											
2-5	Start Time Stamps											
6-9	End Time Stamps											
10	Is Loop, 00: disable, 01: enable											
11	Loop Period, 00=month, 01=day, 02=week											
12-13	Month/day /week interval											
	If loop period is week, Byte 12 : Repeat weekday, per bit 0=Disable, 1=Enable											
	<table border="1"> <thead> <tr> <th>Bit</th> <th>7</th> <th>6</th> <th>...</th> <th>1</th> <th>0</th> </tr> </thead> <tbody> <tr> <td></td> <td>0</td> <td>Sat.</td> <td>...</td> <td>Mon.</td> <td>Sun.</td> </tr> </tbody> </table>	Bit	7	6	...	1	0		0	Sat.	...	Mon.
Bit	7	6	...	1	0							
	0	Sat.	...	Mon.	Sun.							

Action Field:

Byte	Description
1	02
2	01: valve 1 02: valve 2
3	00: close 01: open
4	Time Control, 00: disable 01: enable
5-8	Duration (s)
9	Flow Control, 00: disable 01: enable
10-13	Water Volume (Pulse)

Example: During the time range 2024-3-1 0:00 to 2024-9-1 0:00, open the valve 1 at 0:00 for 5 minutes every 2 days.

If

Time

2024/03/01 00:00 — 2024/09/01 00:00

Then

Valve1 Open

Duration(min)

5

Is Loop

Loop Period

2 Day

ff55 0101 0100aae065003ed36601010200 020101012c0100000000000000					
Channel	Type	Rule ID	Enable	Condition Field	Action Field
ff	55	01	01=enable	Start time: 00aae065=>65e0aa00 = 1709222400 =2024/03/01 00:00:00 End time: 003ed366=>66d33e 00=1725120000=2024/ 0 9/01 00:00:00 01=enable loop, loop period: 01=day 02 00=>00 02=2 days	0101= valve 1 open 01=time con- trol enable 2c 01 00 00=>00 00 01 2c=300s=5 minutes

Condition: Receive D2D command

Condition Field:

Byte	Description
1	02
2-3	D2D Command
4-13	00....00

Action Field:

Byte	Description
1	01
2	01: valve 1 02: valve 2
3	00: close 01: open
4	Time Control, 00: disable 01: enable
5-8	Duration (s)
9	Flow Control, 00: disable 01: enable
10-13	Water Volume (Pulse)

Example: When the device receives Milesight D2D command 0001, it can open solenoid valve2 for 5 minutes.

If

▼
D2D

0001

Then

▼
Valve2
▼
Open

Duration(min)

5

ff55 0a01 020100000000000000000000 010201012c0100000000000000					
Channel	Type	Rule ID	Enable	Condition Field	Action Field
ff	55	0a=>10	01=enable	0100=>00 01 D2D com- mand is 0001	02=valve 2, 01=open 01=time control enable 2c 01 00 00=>00 00 01 2c=300s=5 minutes

Condition: Water Volume

Condition Field:

Byte	Description
1	03
2	01: GPIO1 02: GPIO2
3-4	Period (min)
5-8	Threshold (Pulses)
9-13	00....00

Action Field:

When the action is "Report Interface Status":

Byte	Description
1	03
2	01: Report Interface 1 Status, 02: Report Interface 2 Status
3-13	00...00

When the action is "Custom message content":

Byte	Description
1	03
2	03
3-10	Custom message content

Byte	Description
11-13	000000

Example: When the GPIO2 detects 20 pulses within 2 minutes, the device will report a alarm packet to network server.

If

Water Volume

Water Volume Counter 2

Period(min)

2

Threshold(Pulses)

20

Then

Report counter value and valve status

ff55 0500 03020200 140000000000000000 0303616c61726d000000000000					
Channel	Type	Rule ID	Enable	Condition Field	Action Field
ff	55	05=>5	00=disable	02=GPIO2, 0200=>00 02=2 minutes, 14 00 00 00=>00 00 00 14=20 pulses	Send message: 61 6c 61 72 6d=> 97 108 97 114 109=alarm (hex to ascii)

Condition: Every increase of water volume

Condition Field:

Byte	Description
1	03

Byte	Description
2	01: GPIO1 02: GPIO2
3-6	Threshold (Pulses)
7-13	00....00

Action Field:

When the action is "Report Interface Status":

Byte	Description
1	03
2	01: Report Interface 1 Status, 02: Report Interface 2 Status
3-13	00...00

When the action is "Custom message content":

Byte	Description
1	03
2	03
3-10	Custom message content
11-13	000000

Example: Every time the counter of GPIO2 increases 20, the device will report a custom message to the network server.

If

Every increase of water volume

Water Volume Counter 2

Threshold(Pulses)

20

Then

Report customized message

Message

alarm

ff55 0600 04021400000000000000000000000000 0303616c61726d00000000000000					
Channel	Type	Rule ID	Enable	Condition Field	Action Field
ff	55	06=>6	00=disable	02=GPIO2 1c 00 00 00=>00 00 00 14=20 pulses	Send message: 61 6c 61 72 6d=> 97 108 97 114 109=alarm (hex to ascii)

Enquire the Rule Content

Enquire format:

Channel	Type	Value
ff	53	Rule ID (range: 1-16)

Reply format:

Channel	Type	Rule ID	Enable	Condition Field	Action Field
fe	53	01~10 (1~16)	00: disable 01: enable	See Set the Rule	See Set the Rule

Example: Check rule 10 content.

ff530a		
Channel	Type	Value
ff	53	0a = rule 10

Reply:

fe53 0a01 020100000000000000000000 010201012c0100000000000000					
Channel	Type	Rule ID	Enable	Condition Field	Action Field
fe	53	0a = rule 10	01: enable	0100=>00 01 D2D com- mand is 0001	02=valve 2, 01=open 01=time con- trol enable 2c 01 00 00=>00 00 01 2c=300s=5 minutes

Enquire and Set the Rule Status

The device supports multiple commands for enquiring or setting the rule status. When the device has multiple schedule plan settings that are conflicted, the device will only execute one plan whose item number is largest.

Basic format 1:

Channel	Type	Command	Value
ff	4b	00: get rule status 01: set rule status 02: delete rule	2 Bytes (16 bits), every bit indicate one rule 1: enable ; 0: disable or delete

Basic format 2:

Channel	Type	Command	Rule ID	Enable
ff	4b	03: set one rule status	01~10(1~16)	01: enable

Channel	Type	Command	Rule ID	Enable
		04: delete rule plan		00: disable or delete

Example 1: Check rule enable or disable status.

ff4b000000				
Channel	Type	Command	Value	
ff	4b	00: get rule status	0000	

Reply:

fe4b000200				
Channel	Type	Command	Value	
fe	4b	00: get rule status	02 00 => 00 02 = 0000 0000 0000 0010 => Only rule 2 is enabled, other are disabled or do not have content	

Example 2: Set rule 2 as enable and others as disabled.

Type 1:

ff4b010200				
Channel	Type	Command	Value	
ff	4b	01: set rule status	02 00 => 00 02 = 0000 0000 0000 0010 => Rule 2 are enabled and other are disabled	

Type 2:

ff4b030201				
Channel	Type	Command	Number	Value
ff	4b	03: set one rule status	02	01 = enabled

Example 3: Delete rule 10.

Type 1:

ff4b02fffd			
Channel	Type	Command	Value
ff	4b	02: delete rule	ff fd => fd ff = 1111 1101 1111 1111 => Delete plan 10

Type 2:

ff4b030201				
Channel	Type	Command	Number	Value
ff	4b	04: delete rule	0a = 10	00 = deleted

Historical Data Query Commands

 **Important:**

This feature is only supported in versions prior to V1.4.

UC51x can query historical data for a specified time point or range through downlink commands. The prerequisites are that the device time is correct and the **data storage function** is enabled. The device uploads a maximum of 300 data records per range query. When querying data for a specific time point, the device uploads the record closest to the requested time within the current reporting interval.

For example, with a 10-minute reporting interval, a query for 17:00 will return the exact record if it exists. Otherwise, the device searches for data within a tolerance of ±10 minutes (16:50 to 17:10) and uploads the record closest to 17:00.

Command format:

Item	Channel	Type	Description
Query data for a specified time point	fd	6b	4 Bytes, Unix timestamp
Query data for a specified time range	fd	6c	Start time (4 bytes) + end time (4 bytes), Unix timestamp
Stop data query report	fd	6d	ff
Report interval	ff	6a	3 bytes

Item	Channel	Type	Description
			Byte 1: 01 Byte 2-3: interval time, unit:s, range: 30-1200 s, default: 60s

Reply format:

Channel	Type	Description
fc	6b/6c	00: data query success 01: invalid time point or time range 02: no data for this time point or time range
20	ce	Data time stamp (4B) + Interface Status (1B) + Pulse Counter (4B)

Interface Status:

Bit	Description
7-5	000
4	0: valve 1, 1: valve 2
3	1
2	DI status, 0: closed, 1: open
1	Work Mode, 0: Counter, 1: DI
0	Valve Status, 0: closed, 1: open

Example: Enquire historical data between 2023/03/09 17:00:00 to 2023/03/09 17:10:40.

fd6c 10a00964 90a20964		
Channel	Type	Value
fd	6c (Enquire data in time range)	Start time: 10a00964 => 6409a010 = 1678352400 =2023/03/09 17:00:00

fd6c 10a00964 90a20964		
Channel	Type	Value
		End time: 90a20964 => 6409a290 = 1678353040 =2023/03/09 17:10:40

Reply:

fc6c00		
Channel	Type	Value
fc	6c (Enquire data in time range)	00: data enquiry success

20ce3fa10964009800000020ce3fa109641700000000			
Channel	Type	Time Stamp	Value
20	ce (Historical Data)	3fa10964 => 2023/03/09 17:05:00	00: Valve 1 close 98 00 00 00 => 00 00 00 98 = pulse counter of GPIO1 is 152 17=10111=>Valve 2 open, DI status of GPIO2 is open

Chapter 6. Services

Milesight provides customers with timely and comprehensive technical support services. End-users can contact your local dealer to obtain technical support. Distributors and resellers can contact directly with Milesight for technical support.

Technical Support Mailbox: iot.support@milesight.com

Online Support Portal: <https://support.milesight-iot.com>

Resource Download Center: <https://www.milesight.com/iot/resources/download-center/>

MILESIGHT CHINA

TEL: +86-592-5085280

FAX: +86-592-5023065

Add: Building C09, Software Park Phase III, Xiamen 361024, Fujian, China