

# IUW

## Ultrasonic bulk water meter for use in drinking water distribution and industrial applications

The IUW ultrasonic bulk water meter is used to record high and fluctuating flows in drinking water distribution and in industry, with a very low pressure loss at the same time. Two pairs of ultrasonic sensors ensure optimum measurement accuracy. The IUW is factory-fitted with a 9-digit LCD display and an NFC interface. This enables a subsequent connection of a wM-Bus (OMS) or LoRaWAN®-NDC module. Via the plug and play function of the NDC module, the radio technology set on the meter is automatically adopted by the NDC module. All variants are approved for any installation and are therefore also suitable for riser and downpipe installation. A head-down mounting is also possible. All materials, which are used in the drinking water section, comply with the required standards, guidelines and the current German drinking water approval (other country-specific drinking water approvals on request).



### Performance characteristics at a glance

- Switchable radio technology
- Highest precision and reliability even in case of low flow rates
- Protection class IP68
- No moving parts in the flow sensor
- Insensitive to deposits and particles
- No straight inlet or outlet needed (U0/D0) according to OIML R49 and DIN EN ISO 4064
- Battery powered LCD register with NFC interface
- Smart functions
- Alarm and statistic functions
- Galvanically separated NFC interface
- Battery life > 15 Years
- Operating pressure MAP 16
- Approved in accordance with MID
- Plug and play detection of radio technology via NDC radio module
- Configuration-App
- Mechanical/electromagnetic environment class M2/E2

### Applications

- For measuring the consumption of cold and clean drinking water or service water up to 50° C
- For measuring high flow rates

### AMR options

- NFC interface (= Near Field Data Capture) for connecting an external NDC module and for device configuration

**Technical data**

|  |                                |                   |          |          |          |          |          |          |          |
|--|--------------------------------|-------------------|----------|----------|----------|----------|----------|----------|----------|
| Nominal diameter                           | DN                             | mm                | 50       | 50       | 65       | 65       | 80       | 80       | 100      |
| Permanent Flowrate                         | Q <sub>3</sub>                 | m <sup>3</sup> /h | 25       | 40       | 40       | 63       | 63       | 100      | 100      |
| Attainable measuring range                 | Q <sub>3</sub> /Q <sub>1</sub> | R                 | 500      | 800      | 500      | 800      | 500      | 800      | 500      |
| Standard measuring range <sup>1</sup>      | Q <sub>3</sub> /Q <sub>1</sub> | R                 | 500      | 500      | 500      | 500      | 500      | 500      | 500      |
| Overload Flowrate                          | Q <sub>4</sub>                 | m <sup>3</sup> /h | 31.25    | 50.00    | 50.00    | 78.75    | 78.75    | 125.00   | 125.00   |
| Overload Flowrate max.                     | Q <sub>4M</sub>                | m <sup>3</sup> /h | 55.00    | 55.00    | 87.00    | 87.00    | 138.00   | 138.00   | 220.00   |
| Minimum flowrate <sup>2</sup>              | Q <sub>1</sub>                 | m <sup>3</sup> /h | 0.05     | 0.08     | 0.08     | 0.13     | 0.13     | 0.20     | 0.20     |
| Transitional flowrate <sup>2</sup>         | Q <sub>2</sub>                 | m <sup>3</sup> /h | 0.08     | 0.13     | 0.13     | 0.20     | 0.20     | 0.32     | 0.32     |
| Lower measuring limit                      | -                              | l/h               | 25       | 25       | 40       | 40       | 63       | 63       | 100      |
| Display range                              | min                            | l                 | 1        | 1        | 1        | 1        | 1        | 1        | 1        |
|  | max                            | m <sup>3</sup>    | 999.999  | 999.999  | 999.999  | 999.999  | 999.999  | 999.999  | 999.999  |
| Temperature range                          | -                              | °C                | 0.1 - 50 | 0.1 - 50 | 0.1 - 50 | 0.1 - 50 | 0.1 - 50 | 0.1 - 50 | 0.1 - 50 |
| Operating pressure                         | MAP                            | bar               | 0.3 - 16 | 0.3 - 16 | 0.3 - 16 | 0.3 - 16 | 0.3 - 16 | 0.3 - 16 | 0.3 - 16 |
| Pressure loss class at Q <sub>3</sub>      | Δp                             | bar               | 0.16     | 0.25     | 0.16     | 0.25     | 0.10     | 0.10     | 0.10     |
| Mechanical environmental condition         | -                              | -                 | M2       | M2       | M2       | M2       | M2       | M2       | M2       |
| Electromagnetic ambient class <sup>4</sup> | -                              | -                 | E2       | E2       | E2       | E2       | E2       | E2       | E2       |
| Climatic environment <sup>3</sup>          | -                              | °C                | 5 - 55   | 5 - 55   | 5 - 55   | 5 - 55   | 5 - 55   | 5 - 55   | 5 - 55   |
| Flow profile sensitivity                   | -                              | -                 | U0/D0    | U0/D0    | U0/D0    | U0/D0    | U0/D0    | U0/D0    | U0/D0    |

**Dimensions and weights:**

|                      |    |      |             |             |          |          |                         |                         |                |
|----------------------|----|------|-------------|-------------|----------|----------|-------------------------|-------------------------|----------------|
| Nominal diameter     | DN | mm   | 50          | 50          | 65       | 65       | 80                      | 80                      | 100            |
| Overall length       | L  | mm   | 200/270/300 | 200/270/300 | 200/300  | 200/300  | 200/225/<br>300/350     | 200/225/<br>300/350     | 250/350/360    |
| Height               | H  | mm   | 60          | 60          | 73       | 73       | 94                      | 94                      | 104            |
| Height               | H1 | mm   | 150         | 150         | 165      | 165      | 203                     | 203                     | 221            |
| Width                | B  | mm   | 120x120     | 120x120     | 145x145  | 145x145  | = D                     | = D                     | = D            |
| Width                | B1 | mm   | 135         | 135         | 150      | 150      | < D                     | < D                     | < D            |
| Flange diameter      | D  | mm   | 165         | 165         | 185      | 185      | 200                     | 200                     | 220            |
| Bolt circle diameter | D1 | mm   | 125         | 125         | 145      | 145      | 160                     | 160                     | 180            |
| Number of bolts      | -  | pcs. | 4           | 4           | 4        | 4        | 8                       | 8                       | 8              |
| Screw size           | -  | mm   | M16         | M16         | M16      | M16      | M16                     | M16                     | M16            |
| Bolt diameter        | -  | mm   | 19          | 19          | 19       | 19       | 19                      | 19                      | 19             |
| Weight approx.       | -  | kg   | 7.0/8.8/9.6 | 7.0/8.8/9.6 | 8.7/10.8 | 8.7/10.8 | 11.2/11.6/<br>12.6/13.9 | 11.2/11.6/<br>12.6/13.9 | 13.7/16.2/16.3 |

<sup>1</sup> Other measuring ranges (R) on request

<sup>2</sup> Values refer to standard measuring range

<sup>3</sup> Condensation possible

<sup>4</sup> During electromagnetic interference, there may be disruptions in the data transmission between the NFC interface and the NDC module, which can lead to a lack of radio transmission. However, the counting progress on the measuring device itself is not affected.

Attention: not all versions are available in all markets

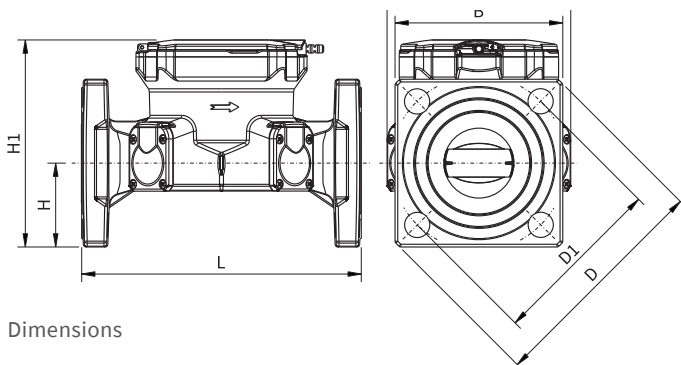

Dimensions

**Technical data**

|  |                                |                   |          |          |          |           |           |           |           |
|--|--------------------------------|-------------------|----------|----------|----------|-----------|-----------|-----------|-----------|
| Nominal diameter                           | DN                             | mm                | 100      | 125      | 125      | 150       | 150       | 200       | 200       |
| Permanent Flowrate                         | Q <sub>3</sub>                 | m <sup>3</sup> /h | 160      | 160      | 250      | 250       | 400       | 400       | 630       |
| Attainable measuring range                 | Q <sub>3</sub> /Q <sub>1</sub> | R                 | 800      | 500      | 800      | 500       | 800       | 500       | 800       |
| Standard measuring range <sup>1</sup>      | Q <sub>3</sub> /Q <sub>1</sub> | R                 | 500      | 500      | 500      | 500       | 500       | 500       | 500       |
| Overload Flowrate                          | Q <sub>4</sub>                 | m <sup>3</sup> /h | 200.00   | 200.00   | 312.50   | 312.50    | 500.00    | 500.00    | 787.5     |
| Overload Flowrate max.                     | Q <sub>4M</sub>                | m <sup>3</sup> /h | 220.00   | 344.00   | 344.00   | 550.00    | 550.00    | 865.00    | 865.00    |
| Minimum flowrate <sup>2</sup>              | Q <sub>1</sub>                 | m <sup>3</sup> /h | 0.32     | 0.32     | 0.50     | 0.50      | 0.80      | 0.80      | 1.26      |
| Transitional flowrate <sup>2</sup>         | Q <sub>2</sub>                 | m <sup>3</sup> /h | 0.51     | 0.51     | 0.80     | 0.80      | 1.28      | 1.28      | 2.01      |
| Lower measuring limit                      | -                              | l/h               | 100      | 100      | 250      | 250       | 250       | 400       | 400       |
| Display range                              | min                            | l                 | 1        | 1        | 1        | 10        | 10        | 10        | 10        |
|  | max                            | m <sup>3</sup>    | 999.999  | 999.999  | 999.999  | 9.999.999 | 9.999.999 | 9.999.999 | 9.999.999 |
| Temperature range                          | -                              | °C                | 0.1 - 50 | 0.1 - 50 | 0.1 - 50 | 0.1 - 50  | 0.1 - 50  | 0.1 - 50  | 0.1 - 50  |
| Operating pressure                         | MAP                            | bar               | 0.3 - 16 | 0.3 - 16 | 0.3 - 16 | 0.3 - 16  | 0.3 - 16  | 0.3 - 16  | 0.3 - 16  |
| Pressure loss class at Q <sub>3</sub>      | Δp                             | bar               | 0.10     | 0.10     | 0.10     | 0.10      | 0.10      | 0.10      | 0.10      |
| Mechanical environmental condition         | -                              | -                 | M2       | M2       | M2       | M2        | M2        | M2        | M2        |
| Electromagnetic ambient class <sup>4</sup> | -                              | -                 | E2       | E2       | E2       | E2        | E2        | E2        | E2        |
| Climatic environment <sup>3</sup>          | -                              | °C                | 5 - 55   | 5 - 55   | 5 - 55   | 5 - 55    | 5 - 55    | 5 - 55    | 5 - 55    |
| Flow profile sensitivity                   | -                              | -                 | U0/D0    | U0/D0    | U0/D0    | U0/D0     | U0/D0     | U0/D0     | U0/D0     |

**Dimensions and weights:**

|                      |    |      |                |      |      |           |           |      |      |
|----------------------|----|------|----------------|------|------|-----------|-----------|------|------|
| Nominal diameter     | DN | mm   | 100            | 125  | 125  | 150       | 150       | 200  | 200  |
| Overall length       | L  | mm   | 250/350/360    | 250  | 250  | 300/500   | 300/500   | 350  | 350  |
| Height               | H  | mm   | 104            | 117  | 117  | 135       | 135       | 162  | 162  |
| Height               | H1 | mm   | 221            | 247  | 247  | 277       | 277       | 326  | 326  |
| Width                | B  | mm   | = D            | = D  | = D  | = D       | = D       | = D  | = D  |
| Width                | B1 | mm   | < D            | < D  | < D  | < D       | < D       | < D  | < D  |
| Flange diameter      | D  | mm   | 220            | 250  | 250  | 285       | 285       | 340  | 340  |
| Bolt circle diameter | D1 | mm   | 180            | 210  | 210  | 240       | 240       | 295  | 295  |
| Number of bolts      | -  | pcs. | 8              | 8    | 8    | 8         | 8         | 12   | 12   |
| Screw size           | -  | mm   | M16            | M16  | M16  | M20       | M20       | M20  | M20  |
| Bolt diameter        | -  | mm   | 19             | 19   | 19   | 23        | 23        | 23   | 23   |
| Weight approx.       | -  | kg   | 13.7/16.2/16.3 | 16.4 | 16.4 | 24.1/29.4 | 24.1/29.4 | 35.5 | 35.5 |

<sup>1</sup> Other measuring ranges (R) on request

<sup>2</sup> Values refer to standard measuring range

<sup>3</sup> Condensation possible

<sup>4</sup> During electromagnetic interference, there may be disruptions in the data transmission between the NFC interface and the NDC module, which can lead to a lack of radio transmission. However, the counting progress on the measuring device itself is not affected.

Attention: not all versions are available in all markets

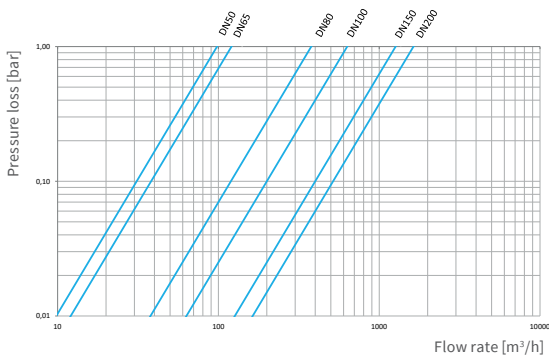

Pressure loss curve

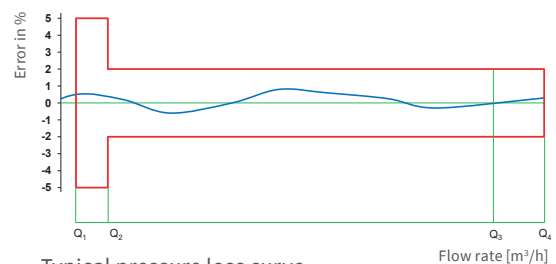

Typical pressure loss curve

**ZENNER International GmbH & Co. KG**

Heinrich-Barth-Straße 29  
66115 Saarbrücken  
Germany

Phone +49 681 99 676-30  
Fax +49 681 99 676-3100  
E-Mail [info@zenner.com](mailto:info@zenner.com)  
Internet [www.zenner.com](http://www.zenner.com)