

zelsius C5-ISF B.One

Thermal energy meter with single-jet flow sensor (ISF)

Optional interfaces: M-Bus, wireless M-Bus, LoRa[®] and 3 pulse inputs or outputs

Nominal sizes: q_p 0.6 to 2.5 m³/h

The thermal energy meter (also called heat or cold meter) zelsius C5-ISF B.One with single-jet flow sensor combines efficiency with compact design, highest precision and most advanced communication interfaces for M-Bus, wireless M-Bus or LoRa[®].

Specially designed for sub-metering applications, it is very well prepared to be used in all real estate with central heat supply:

- Industrial and business buildings
- Apartment buildings and residential complexes
- Multi-family buildings

The advantages of zelsius C5-ISF B.One can be observed even by the installation. With its compact design it is suitable for nearly any installation situation. The combi version with removable calculator allows installation even in the smallest distribution boxes. Zelsius C5-ISF B.One can be easily operated via one single button. The application-oriented display offers an optimum of readability and practical demonstration of relevant operating conditions.

Zelsius C5-ISF B.One is a threaded meter, equipped with a rugged single-jet flow sensor (ISF) with reaction-free electronic impeller detection, available for new installations as well as for simple calibration replacement in all common sizes.



Performance characteristics at a glance

- Available as heat or combined heat/ cooling energy meter as well as glycol meter
- Lowest design height
- Optionally available with M-Bus, wireless M-Bus or LoRa[®] as well with 3 programmable inputs / outputs
- OMS certification for BSI-compliant smart meter gateway connection
- For horizontal and vertical installation position
- Stores monthly readings during the whole running time
- Extensive maximal value storage of thermal output, flow rate and other parameters
- No straight inlet or outlet sections required

Technical data flow sensor type ISF				
Nominal flow q_p	m ³ /h	0.6	1.5	2.5
Maximum flow q_s	m ³ /h	1.2	3.0	5.0
Minimum flow q_i	l/h	12/24	30/60	50/100
Starting flow horizontally ca.	l/h	4	4	5
Pressure loss at q_p	bar	≤0.25		
Medium temperature range	°C	10 ≤ Θ_q ≤ 90		
Minimum pressure (to avoid cavitation)	bar	0.3		
Measurement accuracy class		3		
Nominal pressure / peak pressure	PS/PN	16		
IP protection class		54 (65 for combined heating and cooling energy metering)		
Installation position		horizontal, horizontal tipped through 90° or vertical		
Installation point		return flow, optionally forward flow		
Cable length up to calculator (in combi version)	m	1.2		
Installation place temperature sensors		M10x1		
Heat carrier		water, water-glycol (without Declaration of conformity)		

On-site programmable heat transfer medium for Glycol meter version

Water-Ethylenglycol-Mixture:
Proportion of Ethylene Glycol 20, 25, 30, 35, 40, 45 or 50 %

Water-Propylenglycol-Mixture:
Proportion of Propylene Glycol 20, 25, 30, 35, 40, 45 or 50 %

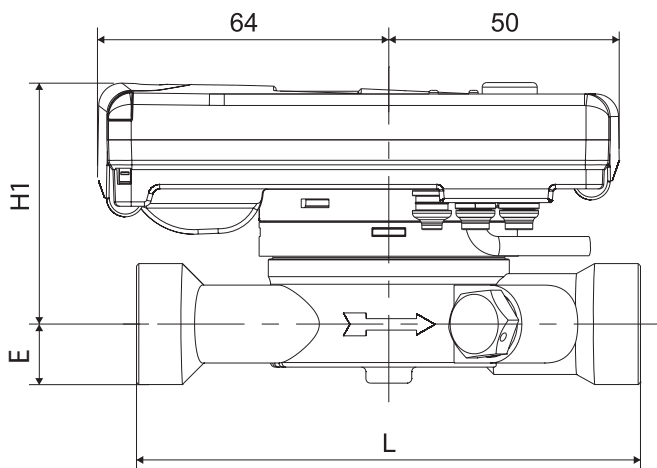

Compact version

Dimensions		
Height compact version		$H_{max} = 55 \text{ mm}$
		$E_{max} = 21 \text{ mm}$
Height combi version	$(H1_{max} + H2)$	$H_{max} = 65 \text{ mm}$
		$H1_{max} = 40 \text{ mm}$
		$H2 = 25 \text{ mm}$
		$E_{max} = 21 \text{ mm}$

Required minimum free space between meter and ceiling min. = 30 mm

Connecting sizes					
Nominal flow	q_p	m ³ /h	0.6	1.5	2.5
Threaded connection	DN	mm	15	15	20
Installation length	L	mm	110	110	130

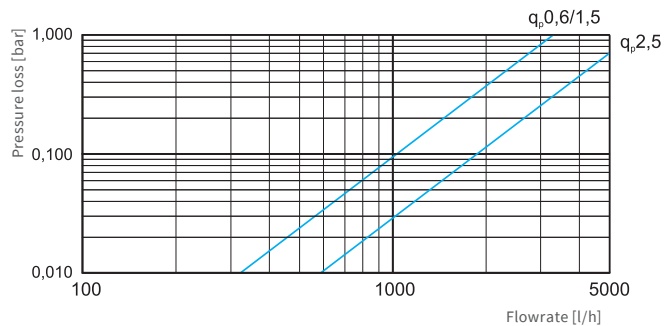

Pressure loss curve

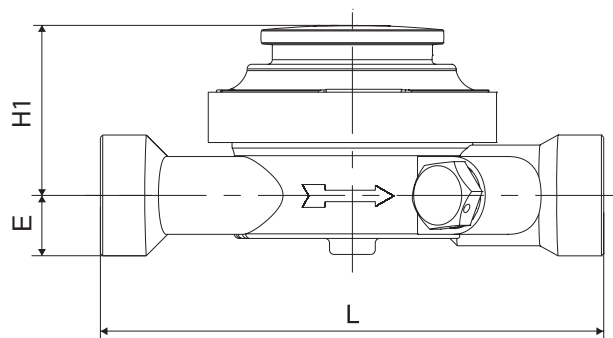
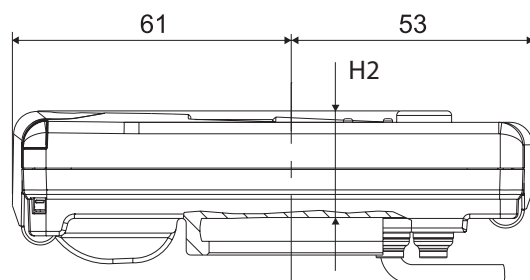

Combi version

Technical data calculator

Temperature range	°C	0...105 ¹
Temperature difference range	K	3...80
Display range		LCD 8-digit + additional character
Ambient temperature	°C	5...55
Storage temperature	°C	-20...+65
Temperature resolution	°C	0.01
Measuring intervals	s	Standard: 30 For models with M-Bus interface: 10 Optional: 4
Heat consumption display		Standard: MWh Optional: kWh, GJ
Data storage		1 x daily
Data log		Annual due date values for heating and/or cooling energy: Storage over the whole running time for readout on the display (the last two annual reference date values can be read out via data telegram)
		Monthly values for heating and/or cooling energy as well as volumes: Storage over the whole running time for readout on the display (the last 24 monthly values can be read out via data telegram)
		Maximum values for flowrate and heating/cooling power: Storage of the absolute values since commissioning the meter as well as 12 monthly values, both with date and time
		Operation hours since commissioning the meter
Interfaces	Standard	optical interface (ZVEI, IrDA)
	optional	<ul style="list-style-type: none"> ■ 3 pulse inputs/ outputs ■ M-Bus (2400 baud, unlimited readout frequency, remote supply via M-Bus level converter, power consumption <1.5 mA, transmission of consumption and instantaneous values) ■ wireless M-Bus: Generation 4, OMS-certified, setting options via app "ZENNER Device Manager Basic": Mode T1 or C1, Encryption Level 5 or 7, various transmission intervals and telegram contents, radio ON / OFF, transmission power: ≤25 mW (14 dBm) ■ LoRa®: Daily values or monthly values (incl. half monthly values), Diagnosis protocol³, Transmission power ≤25 mW (14 dBm)
Power supply		3.6 V lithium battery (different capacities)
Battery lifetime ²	Years	≥7, optional ≥10
IP protection class		54
Ambient class		C
Ambient conditions / climatic influencing (valid for complete compact meter)	- climatic	Highest permissible ambient temperature 55 °C Lowest permissible ambient temperature 5 °C
	- mechanical class	M1
	- electromagnetic class	E1

¹ approx. -20...105 °C for Glycol meter (without Conformity assessment)
² The validity period for the calibration depends on the country, please observe the relevant national regulations.
³ Values for energy and volume increment as well as the average and maximum return temperature within the transmission interval (15 minutes to 1 day can be chosen) are transmitted by the meter. Values for the average supply temperature, temperature difference, thermal power and flowrate are or can be calculated by the LoRa Server based on the energy and volume increment. See also separate description.

Technical data temperature sensors

Platinum precision resistor		Pt 1000
Sensor type ¹	mm	according to the model: 45 x 5.0 mm / 45 x 5.2 mm DS 27.5
Temperature range	°C	0...105
Cable length	m	1.5 (opt. 5)

In the case of new installation of meters with nominal flowrates of ≤ q_p 6 m³/h and nominal pressures of ≤ PN 16 directly immersed in the heat carrier.

Installation point

For calibration exchange in existing measuring points with immersion sleeves with an overall length of ≤ 60 mm, please observe the separate information "Installation in existing immersion sleeves" as well as the immersion sleeve tolerance list from PTB (download at www.ptb.de).

¹ optional

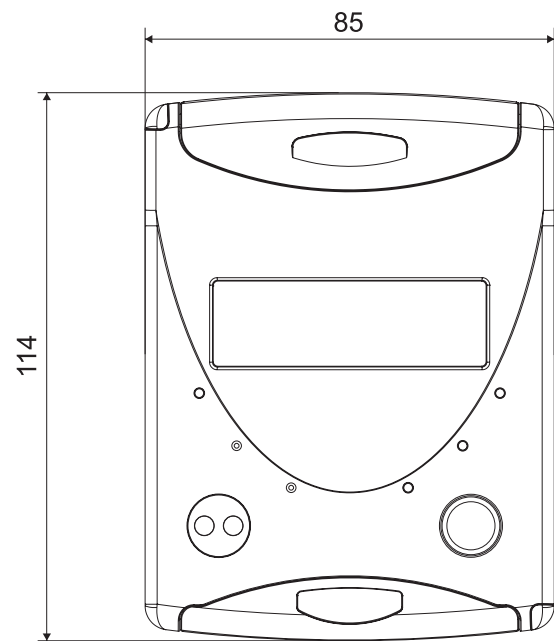

Dimensions data calculator

zelsius C5-ISF B.One

Further zelsius C5-Versions:



zelsius C5-CMF B.One
Compact meter with coaxial measuring
capsule (CMF)



zelsius C5-IUF B.One
Compact meter with ultrasonic
flow sensor (IUF)

ZENNER International GmbH & Co. KG

Heinrich-Barth-Straße 29
66115 Saarbrücken
Germany

Phone +49 681 99 676-30
Fax +49 681 99 676-3100
E-Mail info@zenner.com
Internet www.zenner.com